



KOBALT is a registered trademark of LF, LLC. All Rights Reserved.

ITEM #0358937

7-1/4 IN. SLIDING COMPOUND MITER SAW WITH LASER GUIDE

MODEL #SM1850LW

Français p. 45

Español p. 89

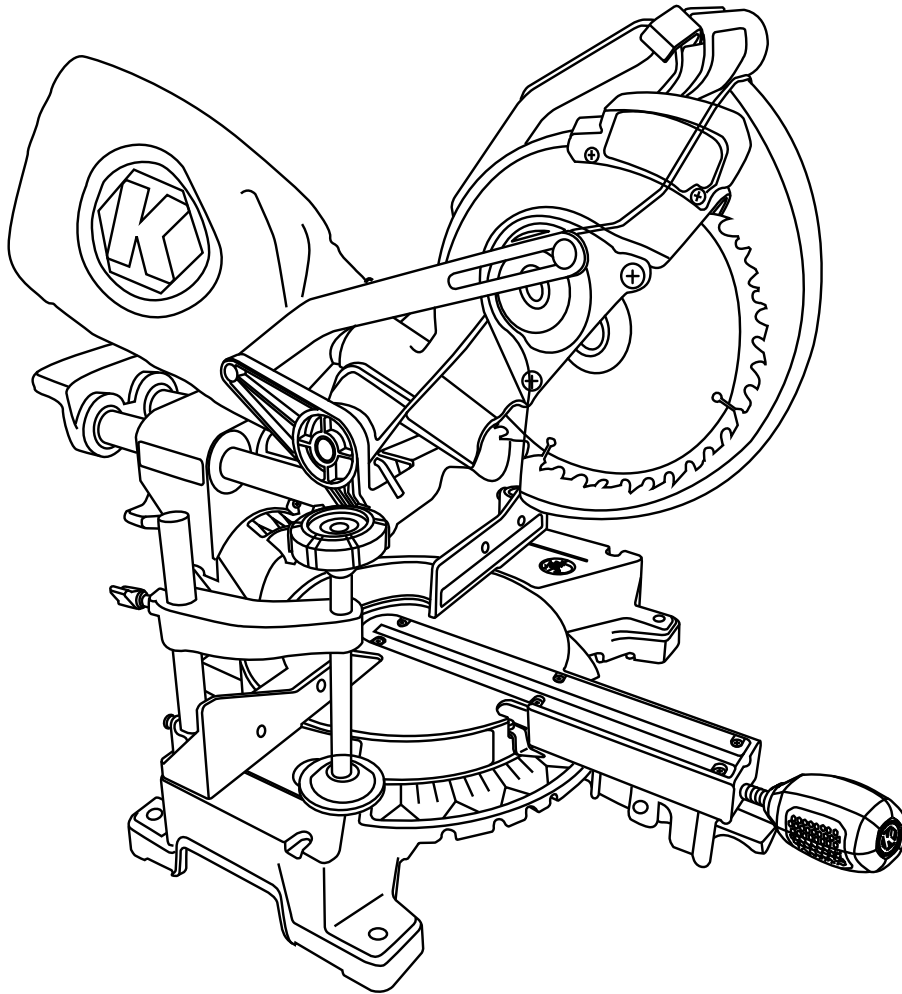

NOTICE: On the nameplate of the machine you will find the serial number and MFG date code of the unit. Please record these numbers on this manual cover for future service reference.

ATTACH YOUR RECEIPT HERE

Serial Number _____ Purchase Date _____



Questions, problems, missing parts? Before returning to your retailer, call our customer service department at 1-888-3KOBALT (1-888-356-2258), 8 a.m. - 8 p.m., EST, Monday - Friday.

TABLE OF CONTENTS

Product Specifications.....	2
Package Contents.....	3
Safety Information.....	4
Preparation.....	10
Assembly Instructions.....	12
Adjustment Instructions.....	14
Operating Instructions.....	23
Crown Moulding Chart.....	33
Care and Maintenance.....	34
Troubleshooting.....	36
Warranty.....	37
Replacement Parts List and Exploded Views.....	38

PRODUCT SPECIFICATIONS

MOTOR		CUTTING CAPACITY	
Power Source	9A, 120V A/C, 60 Hz	Crosscut	2 in. x 8 in.
Arbor Shaft Size	5/8 in.	Miter 45° Right & Left	2 in. x 6 in.
Speed (No load)	5,000 RPM	Bevel 45° Left	1-1/2 in. x 8 in.
Electric Brake	No	45° Miter & 45° Bevel	1-1/2 in. x 6 in.
Double Insulated	Yes	Crown Moulding Nested	3-3/8 in.
BLADE		Base Moulding Against Fence	2-3/4 in.
Diameter	7-1/4 in.	MITER/BEVEL POSITIVE STOP ANGLES	
Arbor	5/8 in.	Miter Detent Stops	0°, 15°, 22.5°, 31.6°, 45° R&L
		Bevel Positive Stops	0°, 45° L

PACKAGE CONTENTS

UNPACKING YOUR MITER SAW

⚠ WARNING: To avoid injury from unexpected starting or electrical shock, do not plug the power cord into a source of power during unpacking and assembly. The cord must remain unplugged whenever you are adjusting/assembling the saw.

1. Remove the miter saw from the carton.

IMPORTANT: Do not lift miter saw by the trigger switch handle. It may cause misalignment. Lift the saw by the hand holds for transportation.

2. Place the saw on a secure, stationary work surface.

3. Separate all parts from the packing material. Check each one with the illustration below to make certain all items are accounted for before discarding any packing material.

⚠ WARNING: If any part is missing or damaged, do not attempt to assemble the miter saw or plug in the power cord until the missing or damaged part is correctly replaced. To avoid electric shock, use only identical replacement parts when servicing double-insulated tools.

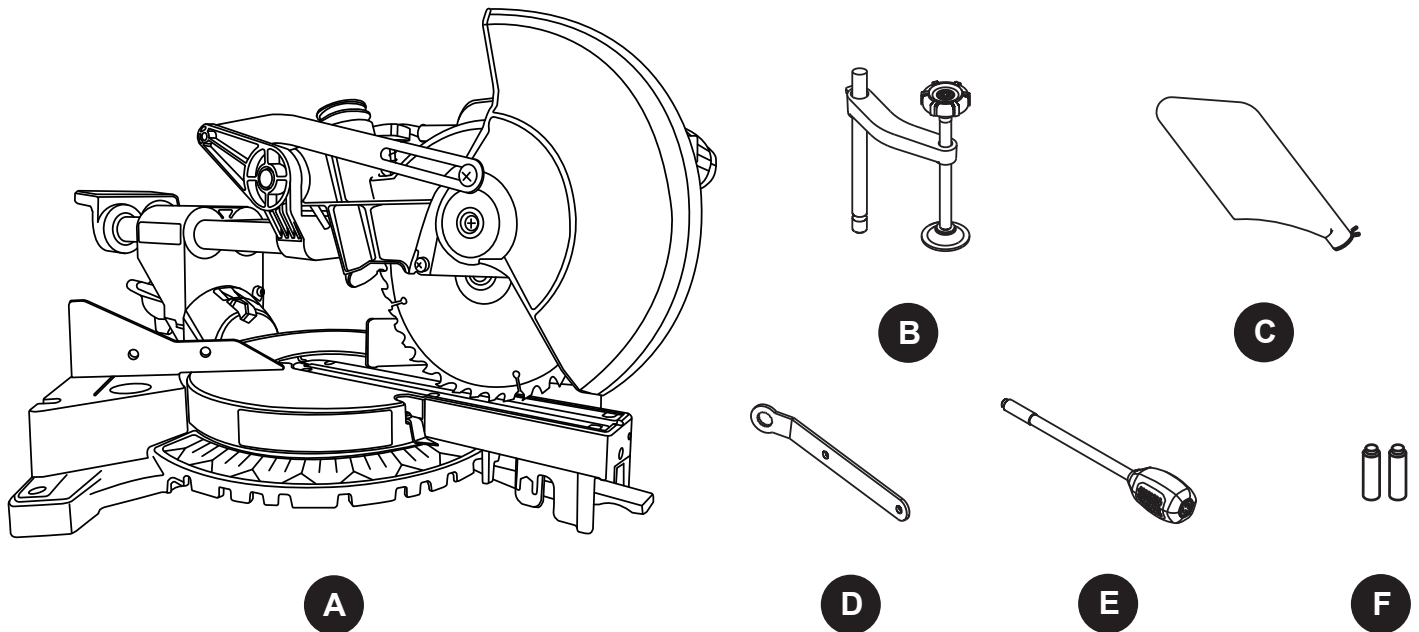

PART	DESCRIPTION	QUANTITY
A	Miter saw	1
B	Hold-down clamp	1
C	Dust bag	1
D	Blade wrench	1
E	Miter handle	1
F	AAA battery	2

SAFETY INFORMATION

GENERAL SAFETY INFORMATION

PROPOSITION 65 WARNING

Some dust created by power sanding, sawing, grinding, drilling and other construction activities contains chemicals known to the State of California to cause cancer, birth defects or other reproductive harm.

Some examples of these chemicals are:

- Lead from lead-based paints,
- Crystalline silica from bricks and cement and other masonry products, and
- Arsenic and chromium from chemically-treated lumber.

Your risk from these exposures varies depending on how often you do this type of work. To reduce your exposure to these chemicals: work in a well ventilated area and work with approved safety equipment, such as dust masks that are specially designed to filter out microscopic particles.

Handling the power cord on this product may expose you to chemicals known to the State of California to cause cancer and birth defects or other reproductive harm. Wash hands after handling.

CAUTION

- Use only the accessories recommended for this miter saw. Follow instructions that accompany the accessories. Use of improper accessories may cause injury.
- The use of any cutting tool except 7-1/4 in. saw blades is prohibited. Do not use accessories such as shaper cutters or dado sets. Ferrous metal cutting, the use of abrasive wheels and the cutting of masonry products are prohibited.
- Do not attempt to modify this tool or create accessories not recommended for use with this tool. Any such alteration or modification is misuse and could result in a hazardous condition leading to possible serious injury.

WARNING

To avoid the risk of personal injury, do not modify this power tool or use accessories not recommended to fit your tool.

WARNING

Read warnings and conditions on your CARBIDE TIPPED SAW BLADE.

- Do not operate the saw without the proper saw blade guard in place.
- Carbide is a very hard but brittle material. Care should be taken while mounting, using and storing carbide tipped blades to prevent accidental damage.
- Slight shocks, such as striking the tip, can seriously damage the blade. Foreign objects in the workpiece, such as wire or nails, can also cause tips to crack or break off.
- Before using, always visually examine the blade and tips for bent teeth, cracks, breakage, missing or loose tips, or other damage.
- Do not use if damage is suspected. Failure to heed safety instructions and warnings can result in serious bodily injury or loss of eyesight.

SAFETY INFORMATION

POWER TOOL SAFETY

Please read and understand this entire manual before attempting to assemble, operate or install the product. These safety instructions are not meant to cover every possible condition that could occur.

GENERAL SAFETY INSTRUCTIONS

- **LEARN** the tool's application, limitations and possible hazards.
- **KEEP GUARDS IN PLACE** and in working order.
- **REMOVE ADJUSTING KEYS AND WRENCHES.** Always check to see that keys and adjusting wrenches are removed from the tool and properly stored before turning it ON.
- **KEEP WORK AREA CLEAN.** Cluttered areas and benches invite accidents.
- **DO NOT USE IN DANGEROUS ENVIRONMENTS.** Do not use power tools in damp locations or expose them to rain or snow. Keep work area well lit.
- **KEEP CHILDREN AWAY.** All visitors and bystanders should be kept at a safe distance from work area.
- **MAKE WORKSHOP CHILDPROOF** with padlocks, master switches or by removing starter keys.
- **DO NOT FORCE THE TOOL.** It will do the job better and is safer if used at the rate for which it was designed.
- **USE THE RIGHT TOOL.** Do not force the tool or an attachment to do a job for which it was not designed.
- **USE PROPER EXTENSION CORDS.** Make sure your extension cord is in good condition. When using an extension cord, be sure to use one heavy enough to carry the current your product will draw. An undersized cord will result in a drop in line voltage and in loss of power that will cause the tool to overheat. The table on page 9 shows the correct size to use depending on cord length and nameplate ampere rating.
- **WEAR PROPER APPAREL.** Do not wear loose clothing, gloves, neckties, rings, bracelets or other jewelry that may get caught in moving parts. Non-slip footwear is recommended. Contain long hair.
- **ALWAYS WEAR EYE PROTECTION.** Any power tool can throw foreign objects into the eyes and could cause permanent eye damage. ALWAYS wear safety goggles (not glasses) that comply with ANSI Safety standard Z87.1. Everyday eyeglasses have only impact-resistant lenses. They ARE NOT safety glasses. **NOTE:** Wearing glasses or goggles not in compliance with ANSI Z87.1 could lead to serious injury.
- **WEAR A FACE MASK OR DUST MASK AND WEAR HEARING PROTECTION.** Operating power tools produces sawdust. Use a dust mask in dusty work conditions. Wear hearing protection during extended periods of operation.
- **SECURE WORK.** Use clamps or a vise to hold work when practical. It is safer than using your hand and it frees both hands to operate the tool.
- **DISCONNECT TOOLS FROM POWER SOURCE** before servicing and when changing accessories, such as blades, bits and cutters.
- **REDUCE THE RISK OF UNINTENTIONAL STARTING.** Make sure switch is in the OFF position before plugging in the tool.
- **USE RECOMMENDED ACCESSORIES.** Consult this Operator's Manual for recommended accessories. The use of improper accessories may lead to risk of injury to yourself or others.
- **NEVER STAND ON THE TOOL.** Serious injury could occur if the tool is tipped or if the cutting tool is unintentionally contacted.
- **CHECK FOR DAMAGED PARTS.** Check the tool for alignment of moving parts, binding of moving parts, breakage of parts or mounting and any other conditions that may affect its operation. Damaged parts should be properly repaired or replaced.
- **NEVER LEAVE THE TOOL RUNNING UNATTENDED. TURN THE POWER OFF.** Do not walk away from a running tool until the blade comes to a complete stop. Unplug the unit.
- **DO NOT OVERREACH.** Keep proper footing and balance at all times.

- **MAINTAIN TOOLS WITH CARE.** Keep tools sharp and clean for best and safest performance. Follow instructions for lubricating and changing accessories.
- **DIRECTION OF FEED.** Feed work into a blade or cutter against the direction of rotation of the blade or cutter.

⚠ CAUTION: Dust generated from certain materials can be hazardous to your health. Always operate the saw in a well-ventilated area and provide for proper dust removal.

⚠ WARNING: People with electronic devices, such as pacemakers, should consult their physician(s) before using this product. Operation of electrical equipment in close proximity to a heart pacemaker could cause interference or failure of the pacemaker.

COMPOUND MITER SAW SAFETY

- **USE ONLY CROSS-CUTTING OR COMBINATION SAW BLADES. IMPORTANT:** The improper blades may deflect and contact the blade guard and will cause possible injury to the operator.
- **DO NOT** operate the miter saw until it is completely assembled and installed according to these instructions.
- **IF YOU ARE NOT** thoroughly familiar with the operation of a miter saw, seek guidance from your supervisor, instructor or other qualified person.
- **ALWAYS** hold the work firmly against the fence and table. **DO NOT** perform any operation free hand. Use clamp whenever possible.
- **KEEP HANDS** out of the path of the saw blade. If the workpiece you are cutting would cause your hands to be within “no-hands zone” area of the saw blade, the workpiece should be clamped in place before making the cut.
- **MAKE SURE** the blade is sharp, runs freely and is free of vibration.
- **ALLOW** the motor to come up to full speed before starting a cut.
- **KEEP THE MOTOR AIR SLOTS CLEAN** and free of chips or dust.
- **ALWAYS MAKE SURE** all handles are tight before cutting, even if the table is positioned in one of the positive stops.
- **MAKE SURE** both the blade and the collar are clean and the arbor bolt is tightened securely.
- **USE** only blade collars specified for your saw.
- **NEVER** use blades larger than 7-1/4 in. diameter.
- **NEVER** apply lubricants to the blade when it is running.
- **ALWAYS** check the blade for cracks or damage before operation. Replace a cracked or damaged blade immediately.
- **NEVER** use blades recommended for operation at less than 5,000 RPM.
- **ALWAYS** keep the blade guards in place and use at all times.
- **NEVER** reach around the saw blade.
- **MAKE SURE** the blade is not in contact with the workpiece before the switch is turned ON.
- **IMPORTANT:** After completing the cut, release the trigger switch and wait for the blade to stop before returning the saw to the raised position.
- **MAKE SURE** the blade has come to a complete stop before removing or securing the workpiece, changing the workpiece angle or changing the angle of the blade.
- **NEVER** cut metals or masonry products with this tool. This miter saw is designed for use on wood and wood-like products.
- **TO PREVENT** severe cuts or injury, clamp all workpieces that can cause your arms, hands or fingers to move within 6-3/4” of the saw blade.
- **PROVIDE** adequate support to the sides of the saw table for long workpieces.
- **NEVER** use the miter saw in an area with flammable liquids or gases.
- **NEVER** use solvents to clean plastic parts. Solvents could possibly dissolve or otherwise damage the material.
- **SHUT OFF** the power before servicing or adjusting the tool.

- **DISCONNECT** the saw from the power source and clean the machine when finished using.
- **SHOULD** any part of your miter saw become missing, damaged, fail in any way or any electrical component fail to perform properly, shut off the switch and remove the plug from the power supply outlet. Replace missing, damaged or failed parts before resuming operation.
- Because of the downward cutting motion, your safety requires that you stay very alert to keeping hands and fingers away from the path that the blade travels.
- Be sure all guards are in place and working. If a guard seems slow to return to its normal position or “hangs up,” adjust or repair it immediately. Be alert at all times - especially during repetitive, monotonous operations. Don’t be lulled into carelessness due to a false sense of security. Blades are extremely unforgiving. Clean the lower guard frequently to help visibility and movement. Unplug before adjustment or cleaning.
- Abrasive cut-off wheels should not be used on miter saws. Miter saw guards are not appropriate for abrasive cut-off wheels.
- To avoid loss of control or placing hands in the path of the blade, hold or clamp all material securely against the fence when cutting. Do not perform operations freehand.
- Support long material at the same height as the saw table.
- Never place your hands or fingers in the path of the blade, or reach in back of the fence. It’s hazardous to do so. Do not cross arms or hands in front of blade to secure workpiece. Use clamps if necessary. Saw blades coast after being turned off. To avoid contact with a coasting blade, do not reach into cutting areas until the blade comes to a full stop.
- After completing a cut, release the trigger switch and allow the blade to come to a complete stop, then raise the saw blade from the workpiece.
- Miter saws have spring loaded saw heads to return the saw head to its up position. Adjust, repair, or replace the spring mechanism if the saw head does not automatically return to its up position when released.
- Hold or clamp the work firmly against the fence on the sawed end.
- Lock the miter saw and blades in the down position during transport or when not in use.
- **DRY RUN** - It is important to know where the blade will intersect with the workpiece during cutting operations.
- Always perform the simulated cutting sequence with the power tool switched OFF to gain an understanding of the projected path of the saw blade.

⚠ WARNING: Additional warnings are listed throughout this manual. Please review all before operating this power tool.

⚠ SAFETY INFORMATION

ELECTRICAL SPECIFICATIONS AND SAFETY

⚠ CAUTION: POWER SUPPLY AND MOTOR

The A/C motor used in this saw is a universal, nonreversible type. See “MOTOR” in the “PRODUCT SPECIFICATIONS” section on page 2.

To avoid electrical hazards, fire hazards or damage to the tool, use proper circuit protection. Your saw is wired at the factory for 120V operation. Connect to a 120V, 15A circuit and use a 15A time-delay fuse or circuit breaker. If power cord is worn or cut or damaged in any way, have it replaced immediately to avoid shock or fire.

DOUBLE INSULATED

This power tool is double insulated to provide a double thickness of insulation between you and the tool’s electrical system. All exposed metal parts are isolated from the internal metal motor components with protective insulation.

REPLACEMENT PARTS – When servicing, use only identical replacement parts. Refer to the Replacement Parts List on pages 38-43.

POLARIZED PLUGS – To reduce the risk of electrical shock, this saw has a polarized plug (one blade is wider than the other). This plug (illustrated at right) will fit in a polarized outlet only one way. If the plug does not fit fully in the outlet, reverse the plug. If it still does not fit, contact a qualified electrician to install the proper outlet. Do not change the plug in any way.

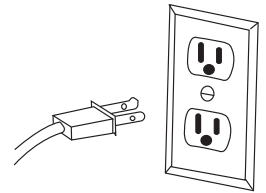

⚠ CAUTION: Double insulation does not take the place of normal safety precautions when operating this tool. To avoid electrocution:

- Use only identical replacement parts when servicing a tool with double insulation. Servicing should be performed by a qualified technician.
- Do not use power tools in wet or damp locations or expose them to rain or snow.

MOTOR SAFETY PROTECTION

⚠ CAUTION: To avoid motor damage, the motor should be blown out or vacuumed frequently to keep sawdust from interfering with motor ventilation.

- **CONNECT** this saw to a 120V circuit. This circuit must not be less than a #18 wire with a 9A time lag fuse.
NOTE: When using an extension cord on a circuit with a #18 wire, the extension cord must not exceed 25 feet in length.
- If the motor will not start, release the trigger switch immediately. **UNPLUG THE SAW.** Check the saw blade to make sure it turns freely. If the blade is free, try to start the saw again. If the motor still does not start, refer to **TROUBLESHOOTING**.
- If the tool suddenly stalls while cutting wood, release the trigger switch, unplug the tool and free the blade from the wood. The saw may now be started and the cut finished.
- **FUSES** may “blow” or circuit breakers may trip frequently if:
 - **MOTOR** is overloaded – overloading can occur if you feed too rapidly or make too many starts/stops in a short time.
 - **LINE VOLTAGE** is more than 10% above or below the nameplate voltage rating. For heavy loads, the voltage at motor terminals must equal the voltage specified on the nameplate.
 - **IMPROPER** or dull saw blades are used.

GUIDELINES FOR EXTENSION CORDS

When using an extension cord, be sure to use one heavy enough to carry the current your product will draw. An undersized cord will cause a drop in line voltage, resulting in loss of power and overheating. The table below shows the correct size to use depending on cord length and nameplate ampere rating. If in doubt, use the next heavier gauge. The smaller the gauge number, the heavier the cord.

MINIMUM GAUGE FOR EXTENSION CORDS (AWG)					
(When using 120 volts only)					
Ampere Rating		Total length of Cord			
More Than	Not More Than	25 ft.	50 ft.	100 ft.	150 ft.
0	6	18	16	16	14
6	10	18	16	14	12
10	12	16	16	14	12
12	16	14	12	Not Recommended	

Be sure your extension cord is properly wired and in good condition. Always replace a damaged extension cord or have it repaired by a qualified person before using it. Protect your extension cords from sharp objects, excessive heat and damp or wet areas.

Use a separate electrical circuit for your tools. This circuit must not be less than #12 wire and should be protected with a 15A time-delay fuse. Before connecting the tool to the extension cord, make sure the saw switch is in the OFF position. The electric circuit should be rated at the same voltage as is stamped on the motor nameplate. Running at a lower voltage will damage the motor.

⚠ CAUTION: In all cases make certain the receptacle in question is properly grounded. If you are not sure, have a certified electrician check the receptacle.

PREPARATION

Before beginning assembly or operation of the product, make sure all parts are present. Compare parts with package contents list and diagram on page 3. If any part is missing or damaged, do not attempt to assemble, install or operate the product.

Estimated Assembly Time: 10 minutes

Tools Required for Assembly (included): Blade Wrench

Tools Required for Assembly (not included): Adjustable Wrench, 2 mm Hex Wrench, 8 mm Hex Wrench, 10 mm Hex Wrench, Combination Square, Phillips Screwdriver, Flathead Screwdriver.

KNOW YOUR MITER SAW

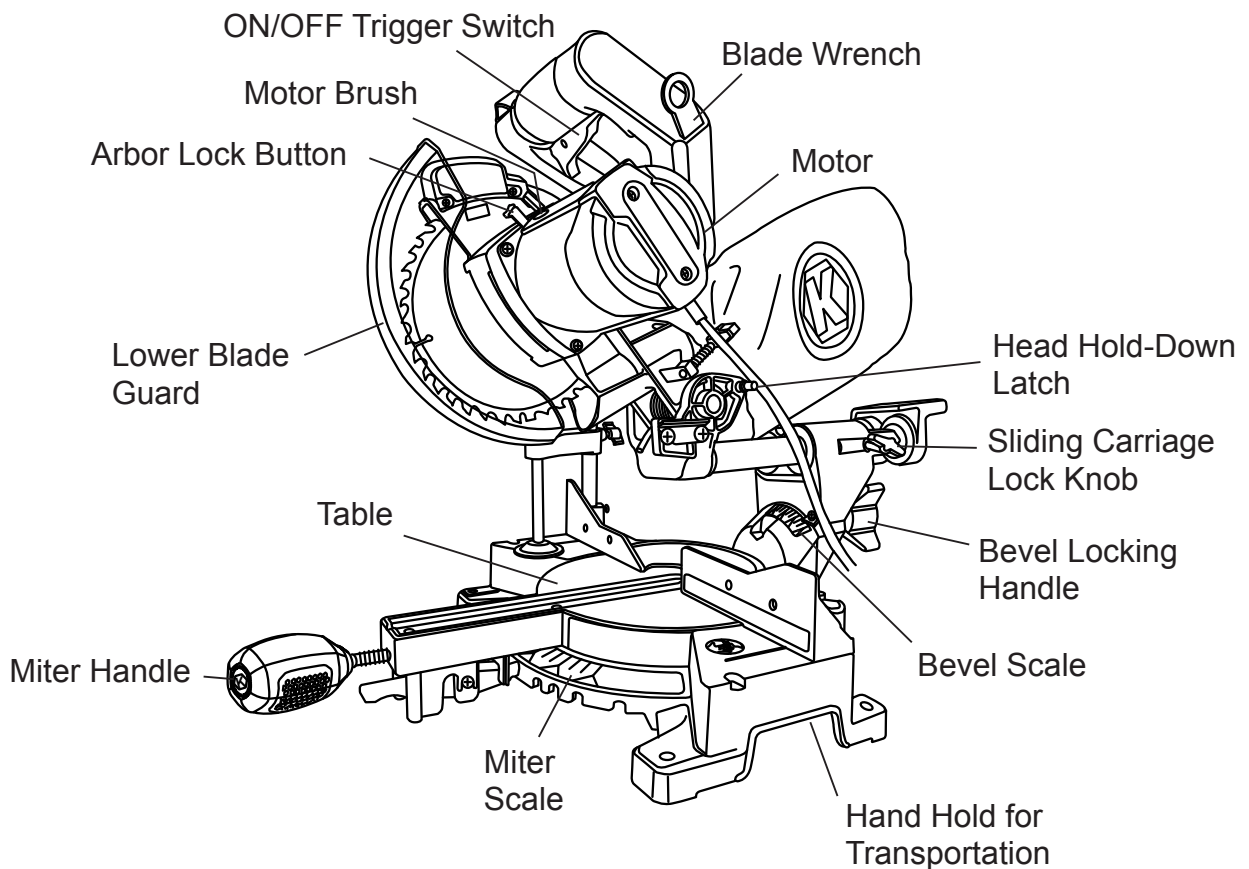
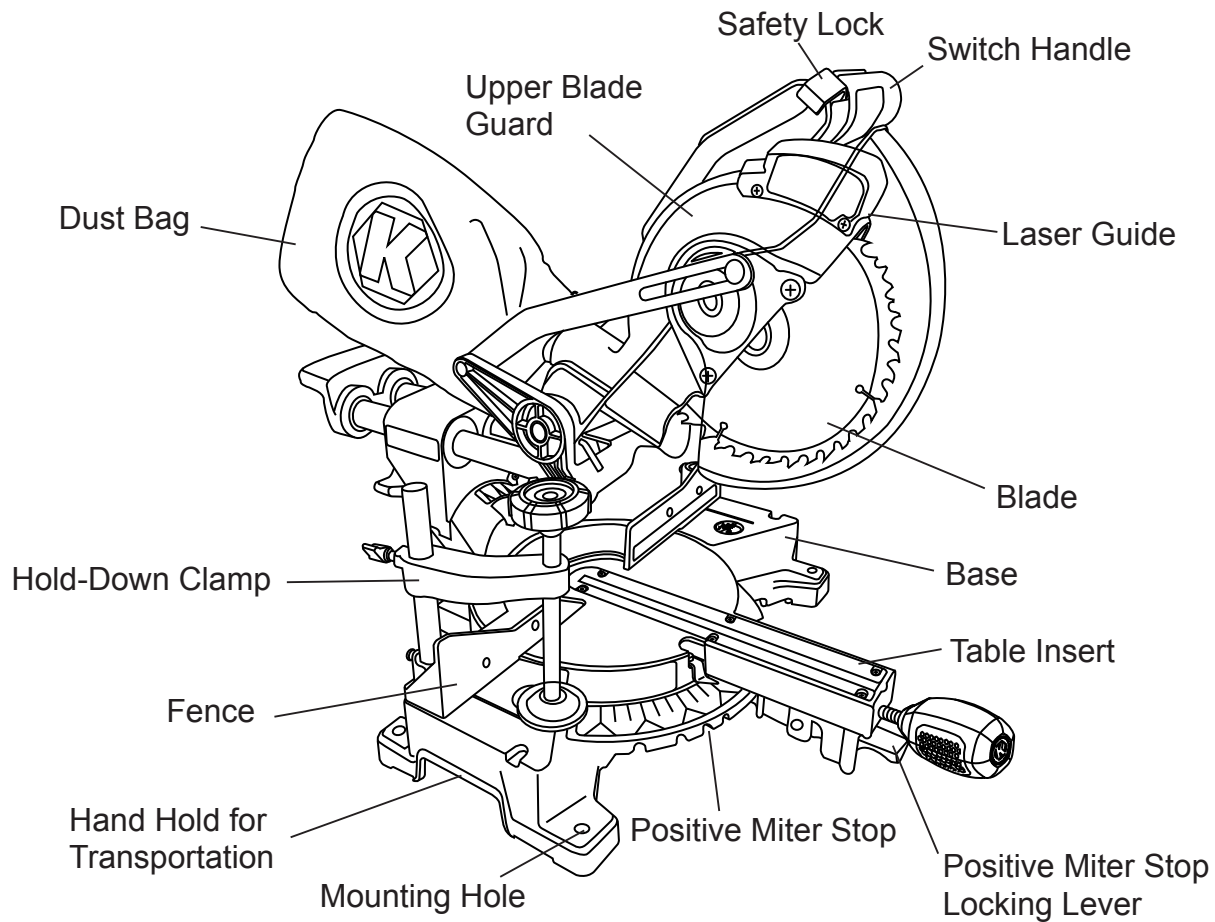

ASSEMBLY INSTRUCTIONS

⚠ WARNING: To avoid injury, do not connect this miter saw to a power source until it is completely assembled and adjusted and you have read and understood the operator's manual.

INSTALLING THE MITER HANDLE (FIG. 1)

- Thread the miter handle (E) into the hole located at the front of the miter saw (A).

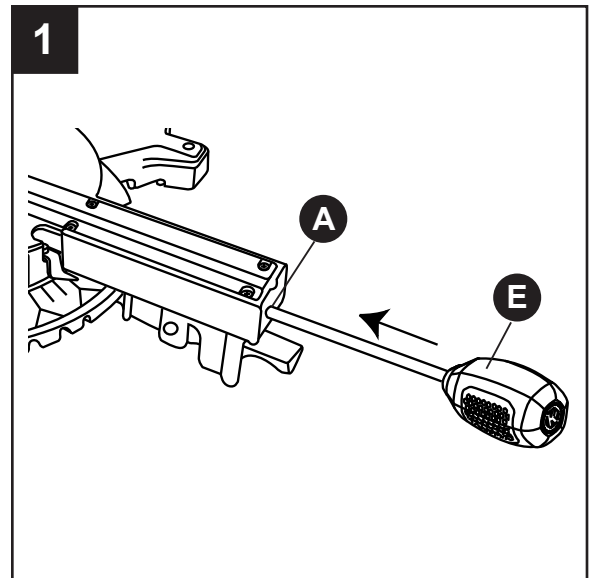

INSTALLING THE DUST BAG (FIG. 2)

- Squeeze the metal collar wings on the dust bag (C).
- Place the dust bag neck opening around the exhaust port on the miter saw (A) and release the metal collar wings.

NOTE: To empty the dust bag, squeeze the metal collar wings and remove from exhaust port. Open zipper on underside of bag and empty into waste container.

IMPORTANT: Check frequently and empty bag before it gets full.

⚠ WARNING: Do not use this saw to cut and/or sand metals. The hot chips or sparks may ignite sawdust from the bag material.

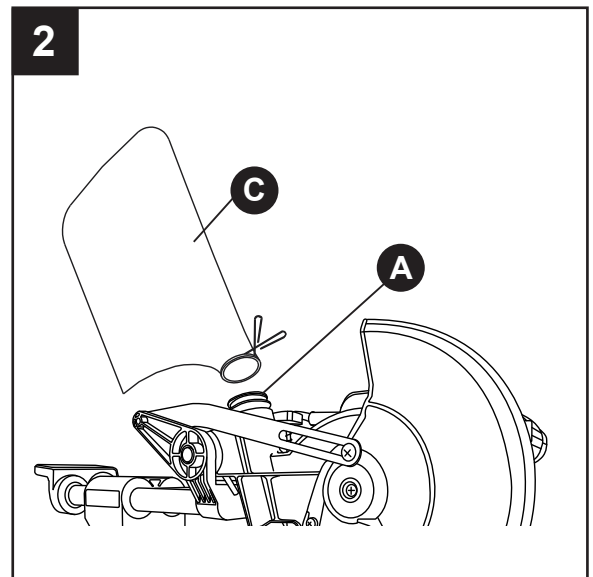

INSTALLING THE HOLD-DOWN CLAMP (FIG. 3)

NOTE: There are two mounting holes for the hold-down clamp. These are located just behind the fence on the left and right side of the base.

- Loosen the screw with a Phillips screwdriver.
- Place the hold-down clamp (B) in the desired mounting hole.
- Tighten the screw to hold the hold-down clamp.

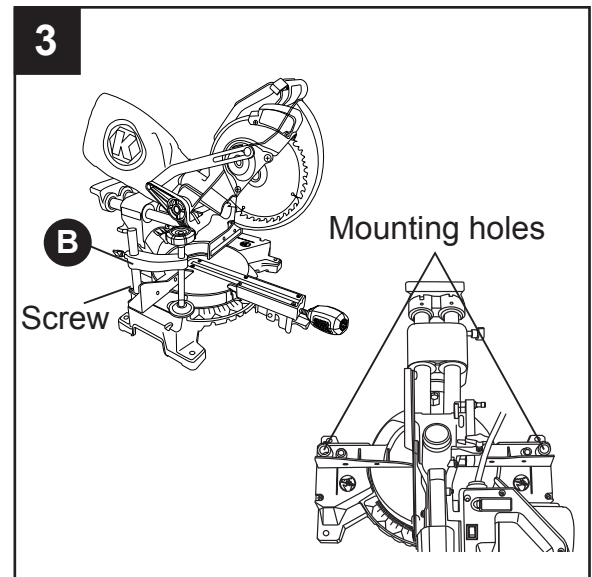

SAW BLADE WRENCH (FIG. 4)

For convenient storage and prevention of loss, there is a slot in the side of the switch handle for storing the blade wrench (D) when not in use.

INSERTING AND REPLACING BATTERIES FOR THE LASER (FIG. 4)

- Unplug your miter saw.

⚠ WARNING: Failure to unplug your tool could result in accidental starting causing possible serious personal injury.

- Open the battery cover located on the switch handle.
- Insert the two supplied AAA batteries (F) as per the diagram. If replacing the batteries, take out the old batteries and replace with new AAA batteries. Dispose of old batteries properly.
- Close the battery cover.

NOTE: Replace with batteries that have a rating of 1.5 volts (Number 4 series and AAA size or equivalent).

HELPFUL HINT: Remove the two batteries during long periods of non-use of the saw. This will reduce damage to the laser guide from the batteries corroding during storage.

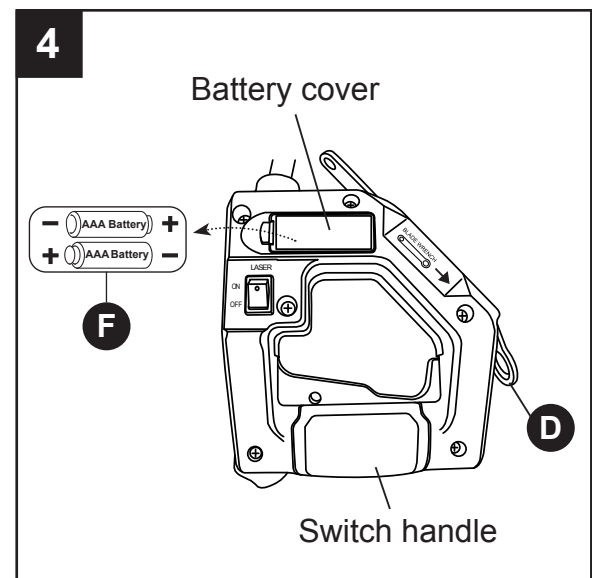

ADJUSTMENT INSTRUCTIONS

UNLOCKING THE SLIDE CARRIAGE (FIG. 5)

- After removing the saw from the carton, loosen the slide carriage lock knob (1). When transporting or storing the miter saw, the slide carriage should always be locked in position. The slide carriage lock knob (1) is located on the right side of the slide carriage.

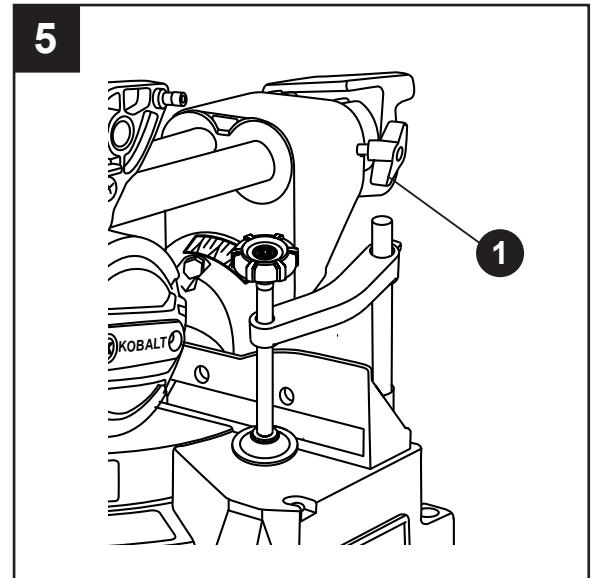

UNLOCKING AND LOCKING THE CUTTER HEAD (FIG. 6)

Unlocking the cutter head:

- To raise the cutter head from its storage/transport position: push down slightly on the switch handle (1).
- Pull out the stop latch knob (2).
- Allow the cutting head to rise to the up position.

Locking the cutting head:

When transporting or storing the miter saw, the cutting head should always be locked in the down position.

- Push the cutting head down to its lowest position.
- Push the stop latch knob (2) into the locking hole.

⚠ CAUTION: To avoid injury and damage to the saw, transport and store the miter saw with the cutting head locked in the down position. Never use the stop latch to hold the cutting head in a down position for cutting operations.

IMPORTANT: To avoid damage, never carry the miter saw by the switch handle, the cutting arm or the miter table handle. ALWAYS use the hand holds for transportation.

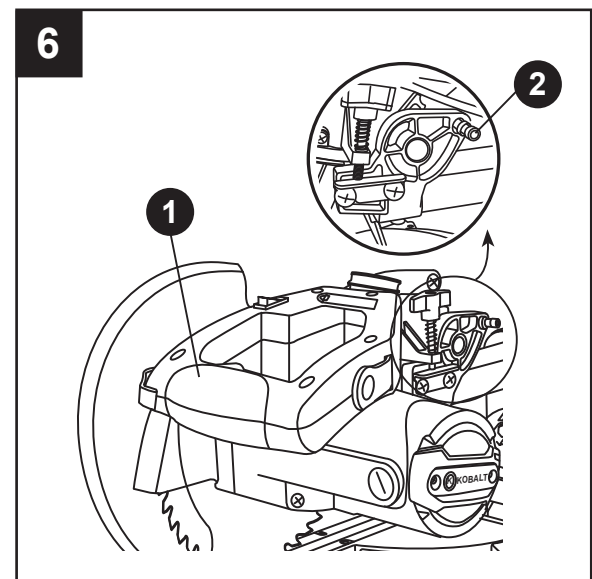

REMOVING AND INSTALLING THE TABLE INSERT (FIG. 7)

NOTE: The miter saw comes with the table inserts already installed. These instructions are for replacing or adjusting either insert side.

⚠ WARNING

To avoid injury:

- Always unplug the saw to avoid accidental starting. Remove all small pieces of material from the table cavity before performing any cuts. The table insert may be removed for this purpose, but always reattach the table insert prior to performing a cutting operation.
- Do not start the sliding compound miter saw without checking for interference between the blade and table insert. Damage could result to the blade, table insert or turntable if blade strike occurs during the cutting operation.
- To remove, loosen and remove the six screws (1) on the table insert (2) with a Phillips screwdriver and remove the insert.
- To install, reposition the table insert, install the six screws and tighten.
- Check for blade clearance by moving the slide carriage through the full motion of the blade in the table slot. If neither side of the insert hits the saw blade, loosen the three screws for that side and adjust. Tighten the screws and check again for blade clearance.

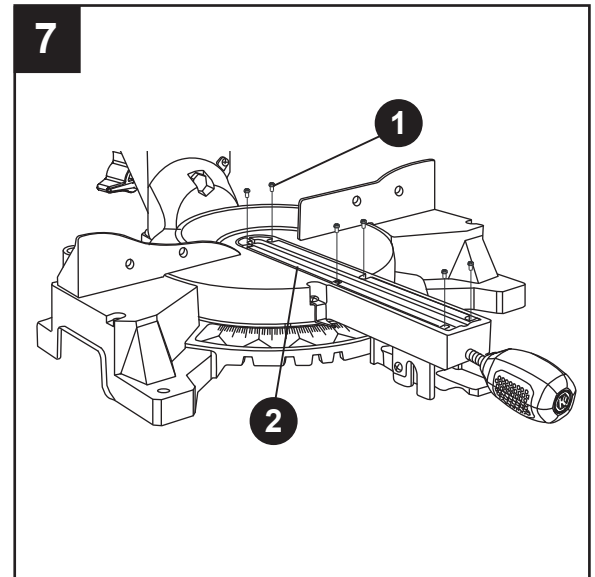

MOUNTING THE MITER SAW (FIG. 8, 9, 10)

⚠ WARNING

To avoid injury from unexpected saw movement:

- Disconnect the power cord from the outlet and lock the cutting head in the lower position using the stop latch.
- Lock the slide carriage in place by tightening the slide carriage lock knob.
- To avoid back injury, lift the saw by using the hand holds for transportation. Bend with your knees, not your back.
- Never carry the miter saw by the power cord or by the switch handle. Carrying the tool by the power cord could cause damage to the insulation or the wire connections resulting in electric shock or fire.
- To avoid injury from flying debris, do not allow visitors to stand near the saw during any cutting operations.

Mounting instructions:

- **For stationary use**, place the saw in the desired location, directly on a workbench where there is room for handling and proper support of the workpiece. The base of the saw has four mounting holes (10) (Fig. 8). Bolt the base of the miter saw (1) to the work surface (5), using the recommended fastening method as shown in Fig. 9.
NOTE: Mounting hardware is not included with this tool. Bolts, nuts, washers and screws must be purchased separately.
- **For portable use**, place the saw on a 3/4 in. thick piece of plywood. Bolt the base of the miter saw securely to the plywood using the mounting holes (10) (Fig. 8) on the base. Use C-clamps to clamp this mounting board to a stable work surface at the worksite (Fig. 10).

NOTE: If a miter saw stand is used, please follow all instructions shown in that product's instructions for proper mounting.

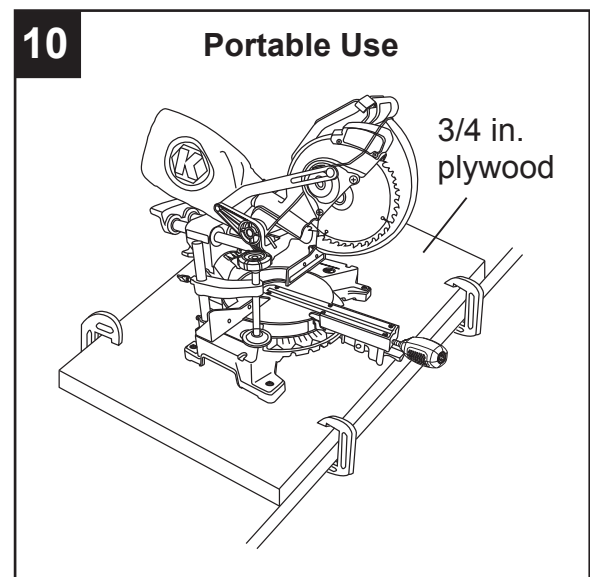
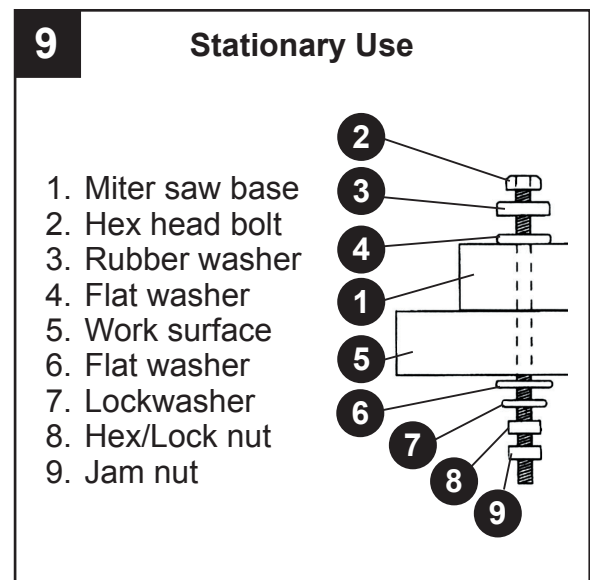
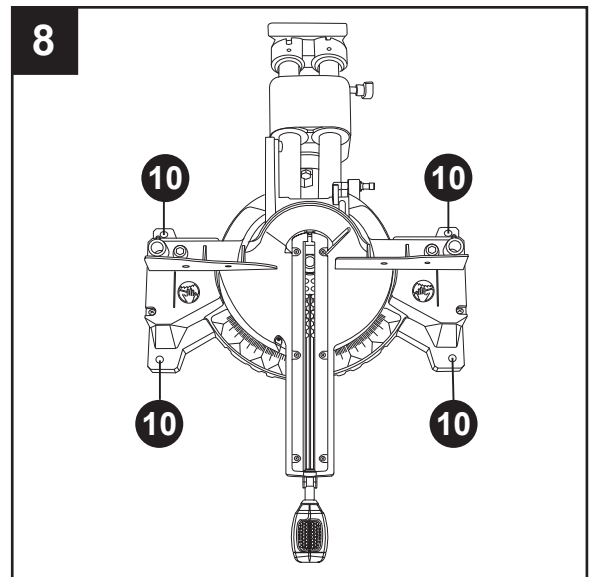

REMOVING AND INSTALLING THE BLADE

⚠ WARNING: Only use a 7-1/4 in. diameter blade. To avoid injury from an accidental start, make sure the switch is in the OFF position and the plug is not connected to the power source outlet.

REMOVING (FIG. 11, 12, 13)

- Unplug the saw from the outlet.
- Allow the miter saw cutting head to rise to the upright position. Raise the lower blade guard (1) to the up position.
- Loosen the cover plate screw (2) with a Phillips screwdriver.
NOTE: Do not remove this screw.
- Rotate the cover plate (3) upward to expose the arbor bolt (4).
- Place the blade wrench over the arbor bolt.
- Locate the arbor lock button (5) on the front of the motor, below the miter saw switch handle (Fig. 12).
- Press the arbor lock button, holding it in firmly while turning the blade wrench clockwise. The arbor lock will engage after turning the wrench. Continue to hold the arbor lock button to keep it engaged, while turning the wrench clockwise to loosen the arbor bolt.
- Remove the arbor bolt (4), the blade collar (6) and the blade (7). Do not remove the inner blade collar (Fig. 13).

NOTE: Pay attention to the pieces removed, noting their position and direction they face. Wipe the blade collar clean of any sawdust before installing a new blade.

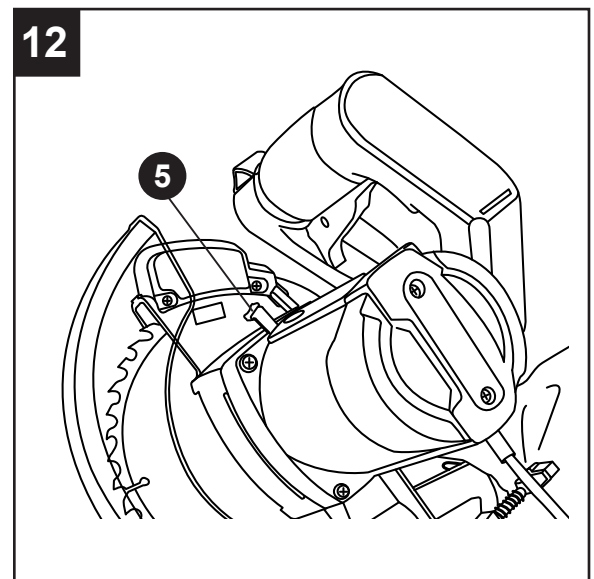
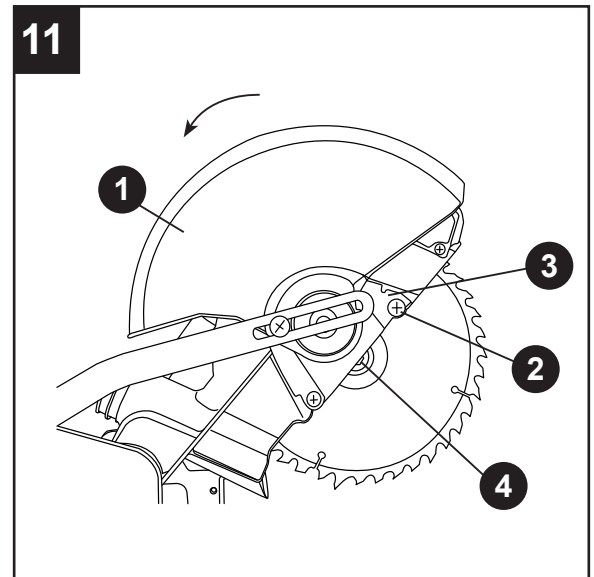

INSTALLING BLADE (FIG. 11, 12, 13)

Unplug the miter saw before changing/installing the blade.

- Install a 7-1/4 in. blade with a 5/8 in. arbor, making sure the rotation arrow on the blade matches the clockwise rotation arrow on the upper guard.
- Place the blade collar (6) against the blade and on the arbor. Thread the arbor bolt (4) onto the arbor (Fig. 13) in a counterclockwise direction.

IMPORTANT: Make sure the flats of the blade collars are engaged with the flats on the arbor shaft. Also, the flat side of the blade collar must be placed against the blade.

- Place the blade wrench on the arbor bolt.
 - Press the arbor lock button (5), holding it in firmly while turning the blade counterclockwise. When arbor lock engages, continue to press it in while tightening the arbor bolt securely (Fig. 12).
 - Rotate the cover plate (3) back to its original position until the slot in the cover plate engages with the cover plate screw (2). While holding the lower blade guard, tighten the screw with a Phillips screwdriver (Fig. 11).
- NOTE:** The lower blade guard must be raised to the upright position to access the cover plate screw.
- Lower the blade guard (1) and verify that the operation of the guard does not bind or stick (Fig. 11).
 - Be sure the arbor lock is released so the blade turns freely before operating the saw.

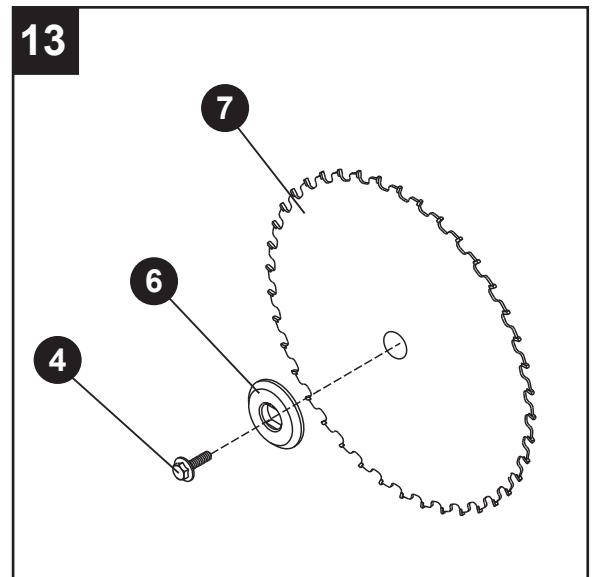

⚠ WARNING

- To avoid injury, never use the saw without the cover plate securely in place. It keeps the arbor bolt from falling out if it accidentally loosens and helps prevent the spinning blade from coming off the saw.
- Make sure the collars are clean and properly arranged. Lower the blade into the lower table and check for any contact with the metal base or the miter table.
- To avoid injury from an accidental start, make sure the switch is in the OFF position and the plug is not connected to the power source outlet.
- Never cut metals or masonry products with this tool. This miter saw is designed for use on wood and wood-like products only.

BEVEL STOP ADJUSTMENT (FIG. 14, 15, 16)

⚠ WARNING: To avoid injury from an accidental start, make sure the switch is in the OFF position and the plug is not connected to the power source outlet.

90° (0°) Bevel Adjustment (FIG. 14):

- Loosen bevel lock handle (1) and tilt the cutting arm completely to the right. Tighten the bevel lock handle.
- Place a combination square (2) on the miter table with the ruler against the table and the heel of the square against the saw blade.
- If the blade is not 90° square with the miter table (5), loosen the bevel lock handle (1), tilt the cutting head to the left, loosen the locknut (4) and turn the bevel angle adjustment bolt (3) in or out with a 10 mm wrench until the blade is square with the table.
- Tilt the cutting arm back to the right at 90° (0°) bevel and recheck for alignment.
- Repeat steps 1 through 4 if further adjustment is needed.
- Tighten bevel lock handle and locknut (4) when alignment is achieved.

90° Bevel Pointer Adjustment (FIG. 15):

- When the blade is exactly 90° to the table, loosen the bevel indicator screw (1) using a Phillips screwdriver.
- Adjust bevel indicator (2) to the "0" mark on the bevel scale and retighten the screw.

⚠ WARNING: To avoid injury from an accidental start, make sure the switch is in the OFF position and the plug is not connected to the power source outlet.

45° Bevel Adjustment (FIG. 16):

- Loosen the bevel lock handle (1) and tilt the cutting head completely to the left.
- Using a combination square, check to see if the blade angle is 45° to the table.
- If the blade is not at 45° to the miter table, tilt the cutting arm to the right, loosen the locknut (2) on the bevel angle adjustment bolt (3) and use a 10 mm wrench to the adjustment bolt (3) depth in or out to increase or decrease the bevel angle.
- Tilt the cutting arm to the left to 45° bevel and recheck for alignment.
- Repeat steps 1 through 4 until the blade is at 45° to the miter table.
- Tighten bevel lock handle (1) and locknut (2) when alignment is achieved.

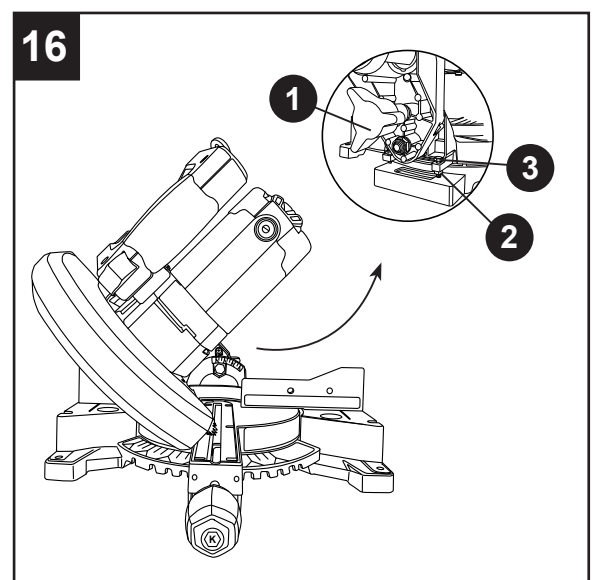
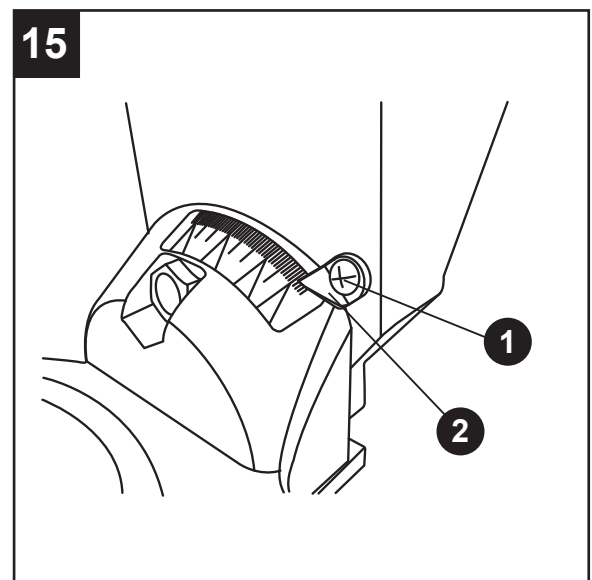
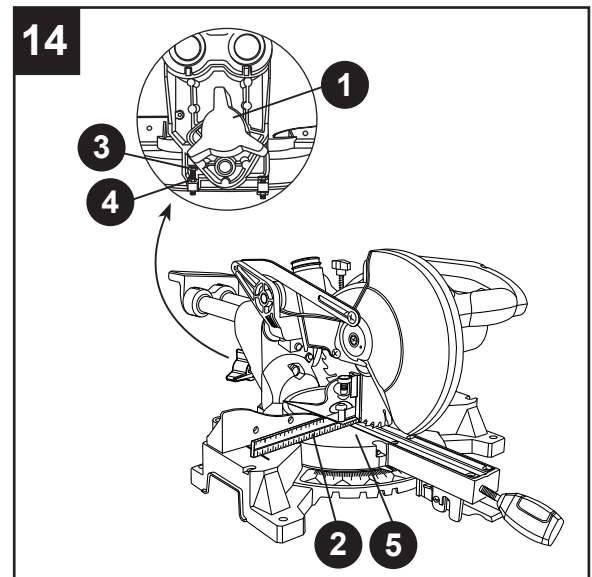

MITER SCALE (FIG. 17)

The sliding compound miter saw scale can be easily read, showing miter angles from 0° to 45° to the left, and 0° to 45° to the right. The miter saw table has nine of the most common angle settings with positive stops at 0°, 15°, 22.5°, 31.6°, and 45°. These positive stops position the blade at the desired angle quickly and accurately. Follow the process below for quickest and most accurate adjustments.

To Adjust Miter Angles:

- Unlock the miter table by turning the miter handle (1) counterclockwise.
- Move the turntable while lifting up on the positive stop locking lever (2) to align the indicator (3) to the desired degree measurement.
- If the desired angle is one of the nine positive stops, release the positive stop locking lever, making sure the lever snaps into position, and then secure by tightening the miter handle.
- If the miter angle desired is not one of the nine positive stops, simply lock the miter table into desired angle position by turning the miter handle in the clockwise direction.

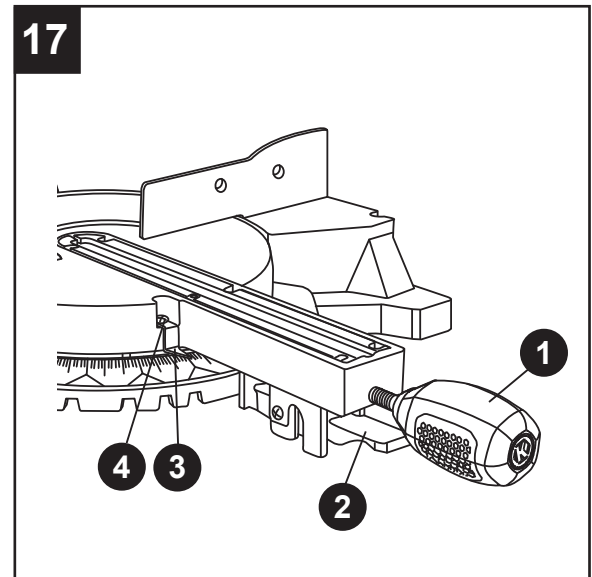

Miter Angle Pointer Adjustment (FIG. 17)

- Move the table to the 0° positive stop.
- Loosen the screw (4) that holds the indicator with a Phillips screwdriver.
- Adjust the indicator (3) to the 0° mark and retighten the screw.

ADJUSTING FENCE SQUARENESS (FIG. 18)

- Lower the cutting arm and lock in position.
 - Using a square (3), lay the heel of the square against the blade and the ruler against the fence (2) as shown.
 - Loosen the two fence locking bolts (1) with an 8 mm hex wrench.
 - Adjust the fence 90° to the blade and tighten the four fence locking bolts.
- NOTE:** If the saw has not been used recently, recheck blade squareness to the fence and readjust if needed.
- After fence has been aligned, make a cut at 90° using a scrap piece of wood and check squareness on the piece. Readjust if necessary.

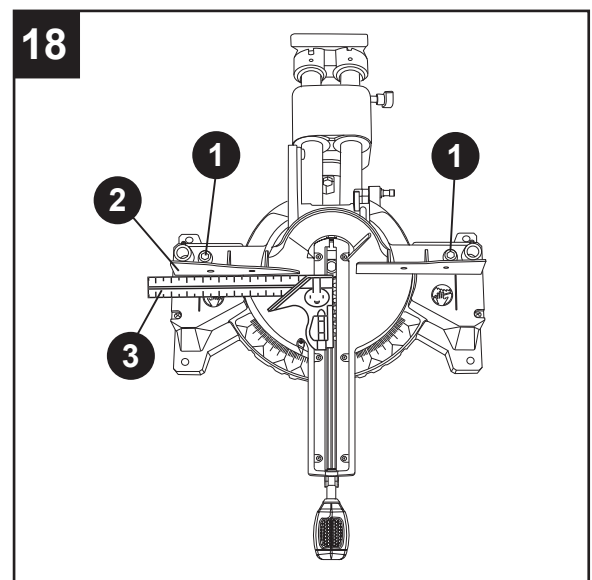

SETTING CUTTING DEPTH (FIG. 19)

The depth of cut can be preset for even and repetitive shallow cuts.

- Adjust the cutting head down until the teeth of the blade are at the desired depth.
- While holding the upper arm in that position, turn the stop knob (1) until it touches the stop plate (2).
- Recheck the blade depth by moving the cutting head front to back through the full motion of a typical cut along the control arm.

MAXIMUM CUTTING DEPTH (FIG. 19)

The maximum depth travel of the cutting head was set at the factory. Check to see that the blade does not extend more than 1/4 in. below the table insert, and does not touch the control arm throat or any part of the base or table. If the maximum depth needs readjusting:

- Loosen the bolts of the stop plate (2).
- Move the cutting head down until the blade extends just 1/4 in. below the table insert.
- Adjust the stop place to touch the bottom of the stop knob (1) when the stop knob is raised fully.
- Recheck the blade depth by moving the cutting head front to back through the full motion of a cut along the control arm. If the blade touches the inside of the control arm, readjust the setting.

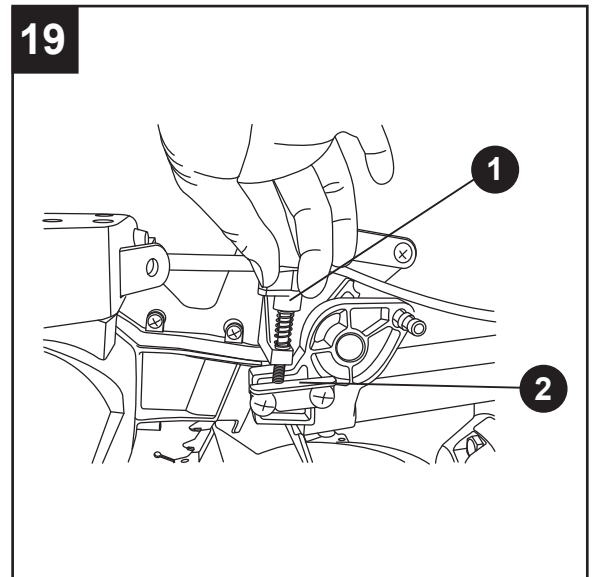

THE LASER GUIDE (FIG. 20, 21)

⚠ WARNING

For your own safety, never connect the plug to a power source outlet until all the adjustment steps are complete and you have read and understood the safety and operational instructions.

Your tool is equipped with a laser guide using a Class IIIa laser beam. The laser beam will enable you to preview the saw blade path on the workpiece to be cut before starting the miter saw. This laser guide is powered by two AAA 1.5 volt batteries.

- To turn laser on, press on/off rocker switch (1) to "ON" position.
- To turn laser off, press on/off rocker switch to "OFF" position.

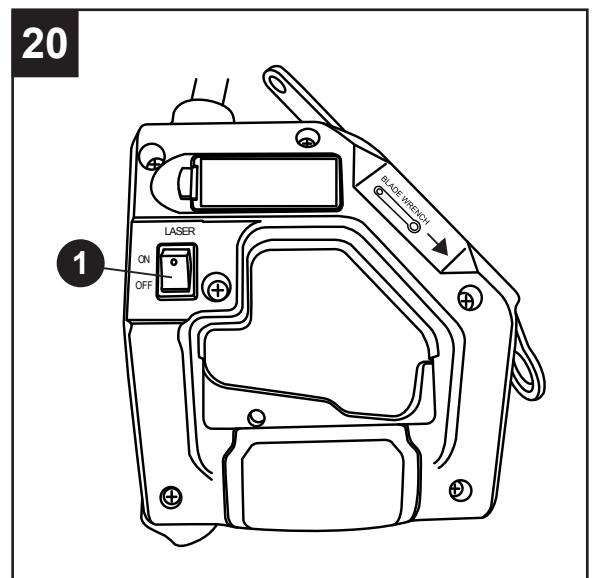

⚠ DANGER: AVOID DIRECT EYE CONTACT

- A red laser line is radiated when the laser guide switch is turned on. Avoid direct eye contact. Always unplug the miter saw from power source before making any adjustments.
- **Laser Warning Label: Max. output < 5 mW, wavelength: 630-660 nm, complies with 21CFR 1040.10 and 1040.11 Class IIIa laser product. (Fig. 21)**
- **Laser Aperture Label: AVOID EXPOSURE: Laser radiation is emitted from this aperture. (Fig. 21)**

NOTE:

- All the adjustments for the operation of this laser guide have been completed at the factory. Laser guide is calibrated and set up to project to the right of the blade (Fig. 22).

⚠ WARNING

- Use of controls or adjustments or performance of procedures other than those specified herein may result in hazardous radiation exposure.

⚠ WARNING

- The use of optical instruments with this product will increase eye hazard.
- Do not attempt to repair or disassemble the laser. If unqualified persons attempt to repair this laser product, serious injury may result. Any repair required on this laser product should be performed by authorized service center personnel.

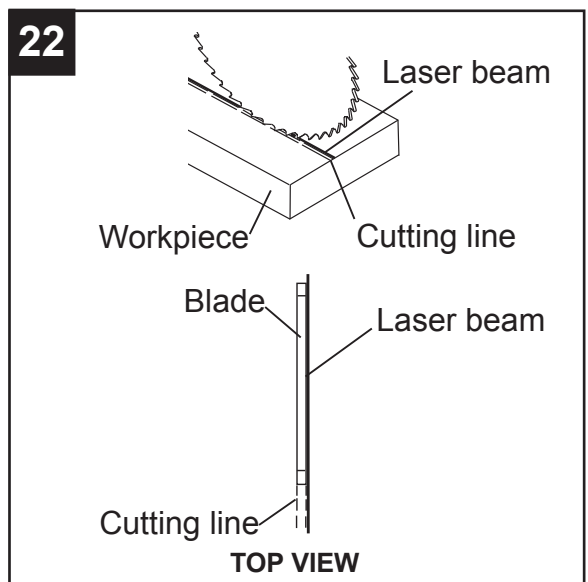
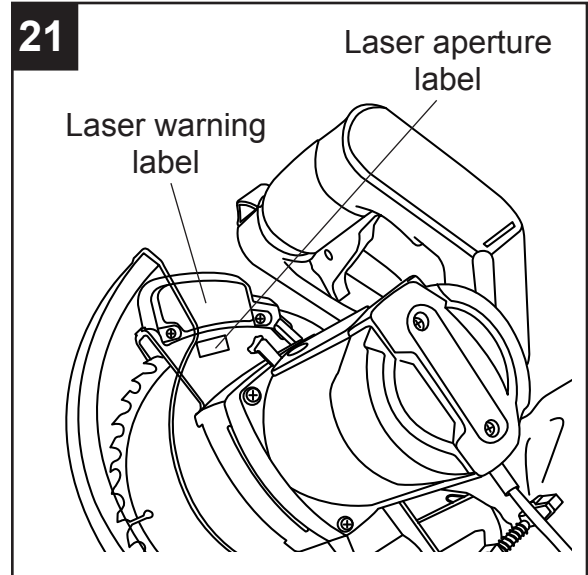

OPERATING INSTRUCTIONS

BEFORE USING THE MITER SAW

⚠️ WARNING: To avoid mistakes that could cause serious, permanent injury, do not plug the tool in until the following steps are completed:

- Completely assemble and adjust the saw, following the instructions (SEE ASSEMBLY AND ADJUSTMENTS SECTIONS).
- Learn the use and function of the ON/OFF switch, upper and lower blade guards, stop latch, bevel lock handle and cover plate screws.
- Review and understand all safety instructions and operating procedures in this Operator's Manual (SEE SAFETY & OPERATIONS SECTIONS).
- Review the MAINTENANCE and TROUBLESHOOTING for your miter saw.
- To avoid injury or possible death from electrical shock, make sure your fingers do not touch the plug's metal prongs when plugging or unplugging your miter saw (SEE ELECTRICAL REQUIREMENTS AND SAFETY SECTIONS).

BEFORE EACH USE

Inspect your saw.

- Disconnect the miter saw. To avoid injury from accidental starting, unplug the saw before making any adjustments, including setup and blade changes.
- Compare the direction of rotation arrow on the guard to the direction arrow on the blade. The blade teeth should always point downward at the front of the saw.
- Tighten the arbor bolt.
- Tighten the cover plate screw.
- Check for damaged parts, including:
 - Alignment of moving parts
 - Damaged blade teeth
 - Damaged electric cords
 - Binding of moving parts
 - Mounting holes
- Function of arm return spring and lower guard: Push the cutting arm all the way down and then let it rise until it stops. The lower guard should close fully. Follow the instructions in the Troubleshooting for adjustment, if necessary.
- Keep all guards in place, in working order and properly adjusted. If any part of this miter saw is missing, damaged or broken, or any electrical parts do not work, turn off the saw and unplug it. Replace damaged, missing or defective parts before using the saw again.
- Maintain tools with care. Keep the miter saw clean for best and safest performance. Follow instructions for lubricating. Do not apply lubricants to the blade while it is spinning.
- Remove all adjusting wrenches from the tool before turning it on.

USE ONLY THE RECOMMENDED ACCESSORIES

- Follow the instructions that come with the accessory. The use of improper accessories may cause risk of injury to persons.
- Choose the correct 7-1/4 in. blade for the material and the type of cutting you plan to do.
- Make sure the blade is sharp, undamaged and properly aligned. With the saw unplugged, push the cutting arm all the way down. Manually spin the blade and check for clearance. Tilt the miter head to a 45° bevel and repeat the test.
- Make sure the blade and arbor collars are clean.
- Make sure all clamps and locks are tight and there is no excessive play in any parts.

KEEP YOUR WORK AREA CLEAN

Cluttered areas and benches invite accidents.

⚠ WARNING: To avoid burns or other fire damage, never use the miter saw near flammable liquids, vapors or gases.

- Plan ahead to protect your eyes, hands, face and ears.
- Read and understand the operator's manual and labels affixed to the tool. Learn its application and limitations as well as the potential hazards specific to this tool. To avoid injury from accidental contact with moving parts, do not layout, assemble or set up work on the miter saw.
- Avoid accidental starting. Make sure the switch is in the OFF position before plugging the miter saw into a power outlet.

PLAN YOUR WORK

Use the right tool. Do not force a tool or attachment to do a job it was not designed to do. Use a different tool for any workpiece that cannot be held in a solidly braced, fixed position.

⚠ WARNING

This machine is NOT designed for cutting masonry, masonry products or ferrous metals (steel, iron and iron-based metals). Use this miter saw to cut only wood and wood by-products. Other materials may shatter, bind the blade or create other dangers. Remove all nails that may be in the workpiece to prevent sparking that could cause a fire.

DRESS FOR SAFETY

Any power tool can throw foreign objects into the eyes. This can result in permanent eye damage. Everyday eyeglasses have only impact resistant lenses and are not safety glasses. Glasses or goggles not in compliance with ANSI Z87.1 could seriously injure you if they break.

- Do not wear loose clothing, gloves, neckties or jewelry (rings, watches). They can get caught and draw you into moving parts.
- Wear non-slip footwear.
- Tie back long hair.
- Roll long sleeves above the elbow.
- Noise levels vary widely. To avoid possible hearing damage, wear earplugs when using any miter saw.
- For dusty operations, wear a dust mask along with safety goggles.

INSPECT YOUR WORKPIECE

- Make sure there are no nails or foreign objects in the part of the workpiece being cut.
- Plan your work to avoid small pieces that may bind or are too small to clamp and hold securely.
- Plan the way you will grasp the workpiece from start to finish. Avoid awkward operations and hand positions. A sudden slip could cause your fingers or hand to move into the blade.

DO NOT OVERREACH

Keep good footing and balance. Keep your face and body to one side, out of the line of a possible kickback. NEVER stand in the line of the blade.

Never cut freehand:

- Brace your workpiece firmly against the fence and table stop so it will not rock or twist during the cut.
- Make sure there is no debris between the workpiece and the table or fence. Make sure there are no gaps between the workpiece, fence and table that will let the workpiece shift after it is cut.
- Keep the cut piece free to move sideways after it is cut off. Otherwise, it could get wedged against the blade and thrown violently.
- Only the workpiece should be on the saw table.
- Secure work. Use clamps or a vise to help hold the work when it is practical.

USE EXTRA CAUTION WITH LARGE OR ODD SHAPED WORKPIECES

- Use extra supports (tables, sawhorses, blocks, etc.) for workpieces large enough to tip.
- Never use another person as a substitute for a table extension or as an additional support for a workpiece that is longer or wider than the basic miter saw table, or to help feed, support or pull the workpiece.
- Do not use this saw to cut small pieces. If the workpiece being cut would cause your hand or fingers to be within 6-3/4 in. of the saw blade, the workpiece is too small. Keep hands and fingers out of the “no-hands zone” area marked on the saw table.
- When cutting odd shaped workpieces, plan your work so it will not bind in the blade and cause possible injury. Moulding, for example, must lie flat or be held by a fixture or jig that will not let it move when cut.
- Properly support round material such as dowel rods or tubing, which have a tendency to roll when cut, causing the blade to “bite.”

 **WARNING:** To avoid injury, follow all applicable safety instructions when cutting non-ferrous metals:

- Use only saw blades specifically recommended for non-ferrous metal cutting.
- Do not cut metal workpieces that must be hand held. Clamp workpieces securely.
- Cut non-ferrous metals only if you are under the supervision of an experienced person.

WHEN SAW IS RUNNING

WARNING

Do not allow familiarity from frequent use of your miter saw to result in a careless mistake. A careless fraction of a second is enough to cause severe injury.

Before cutting, if the saw makes an unfamiliar noise or vibrates, stop immediately. Turn the saw OFF. Unplug the saw. Do not restart until you find and correct the problem.

BODY AND HAND POSITION (FIG. 23)

⚠ WARNING

Never place hands near the cutting area. Proper positioning of your body and hands when operating the miter saw will make cutting easier and safer. Keep children away. Keep all visitors at a safe distance from the miter saw. Make sure bystanders are clear of the saw and workpiece. Do not force the saw. It will do the job better and safer at its designed rate.

⚠ WARNING

Operator and all by-standers must wear proper safety goggles that comply with OSHA/ANSI requirements Z87.1

Starting a cut:

- Place hands at least 6-3/4 in. away from the path of the blade – out of the “no-hands zone.”
- Hold workpiece firmly against the fence to prevent movement toward the blade.
- With the power switch OFF, bring the saw blade down to the workpiece to see the cutting path of the blade.
- Squeeze trigger switch to start saw.
- Lower blade into workpiece with a firm downward motion.

Finishing a cut:

- Hold the cutting arm in the down position.
- Release trigger switch and wait for all moving parts to stop before moving your hands and raising the cutting arm.
- If the blade doesn't stop within 10 seconds, unplug the saw and follow the instructions in TROUBLESHOOTING.

Before freeing jammed material:

- Release trigger switch.
- Wait for all moving parts to stop.
- Unplug the miter saw.

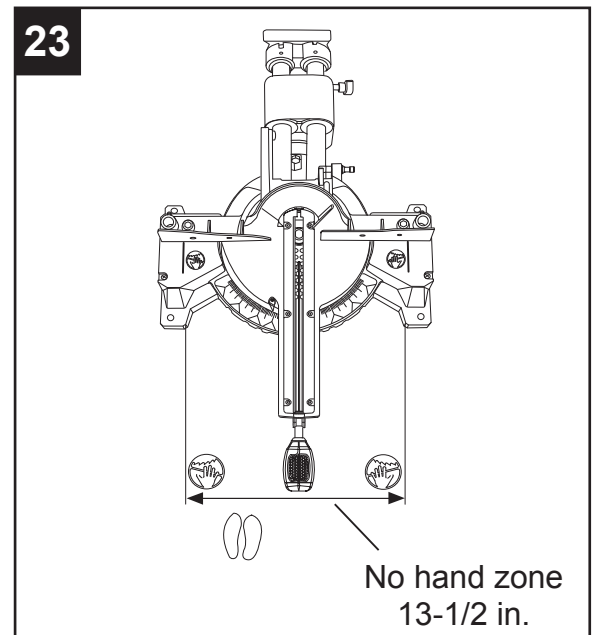

BASIC SAW OPERATIONS

TURNING THE LASER GUIDE ON (FIG. 24)

Press the on/off rocker switch (1) to "ON" position to activate the laser guide.

TURNING THE SAW ON (FIG. 24)

This miter saw is equipped with an ON/OFF trigger switch (2). With the safety lock (3) pressed, squeeze the trigger switch to turn the miter saw ON.

NOTE: Make the ON/OFF switch childproof. Insert a padlock or chain with a padlock (not included) through the hole (4) in the trigger switch, locking the tool's switch and preventing children and other unauthorized users from turning the machine on.

When the trigger switch is released, the blade will be stopped within 10 seconds.

WARNING

- To avoid injury, after completing a cut and releasing the trigger switch, wait and confirm the blade has stopped before raising the cutting head.
- To avoid injury, check and tighten the arbor bolt periodically.

SLIDING CARRIAGE SYSTEM (FIG. 25)

CAUTION: To reduce the risk of injury, return carriage to the full rear position after each crosscut operation.

- For chop cutting operations on small workpieces, slide the cutting head assembly completely toward the rear of the unit and tighten the carriage lock knob (1).
- To cut wide boards up to 8 in., the carriage lock knob (1) must be loosened to allow the cutting head to slide freely.

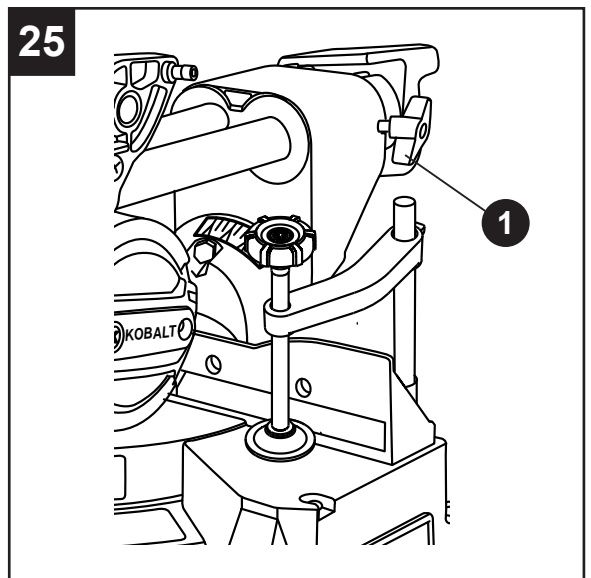
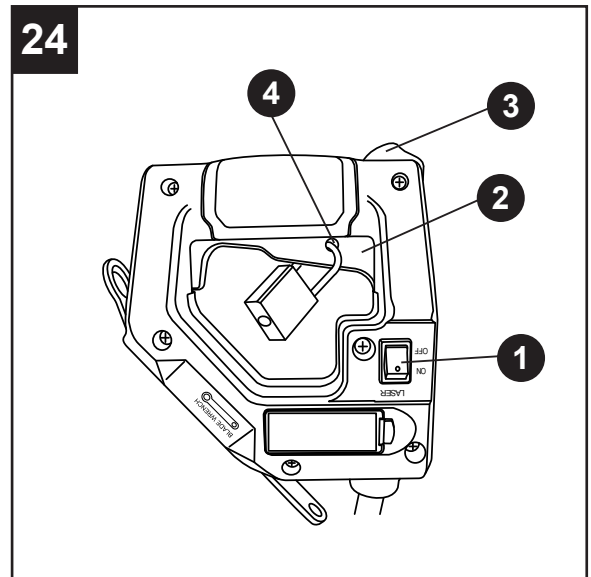

BEFORE LEAVING THE SAW

- Never leave tool running unattended. Turn power OFF. Wait for all moving parts to stop.
- Make workshop childproof. Lock the shop. Disconnect master switches. Store tool away from children and other unqualified users.

⚠ WARNING: To avoid injury from materials being thrown, always unplug the saw to avoid accidental starting and remove small pieces of material from the table cavity.

MITER CUT (FIG. 26)

- When a miter cut is required, unlock the miter table by turning the miter handle (1) counterclockwise.
 - While holding the miter handle, lift up on the positive stop locking lever (2).
 - Rotate the miter table to the right or left with the miter handle.
 - When the table is in the desired position, as shown on the miter scale (3), release the positive stop locking lever and tighten the miter handle.
- The table is now locked at the desired angle. Positive stops are provided at 0°, 15°, 22.5°, 31.6° and 45°.

IMPORTANT: Always tighten the miter table lock handle before performing every cutting operation.

BEVEL CUT (FIG. 27)

- When a bevel cut is required, loosen the bevel lock handle (1) by turning it clockwise.
- Tilt the cutting head to the desired angle, as shown on the bevel scale (2).
- The blade can be positioned at any angle, from a 90° straight cut (0° on the scale) to a 45° left bevel. Tighten the bevel lock handle (1) to lock the cutting head in position. Positive stops are provided at 0° and 45°.

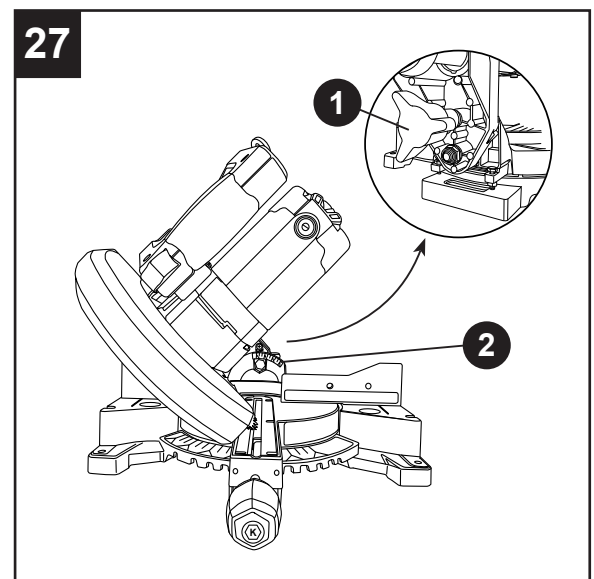
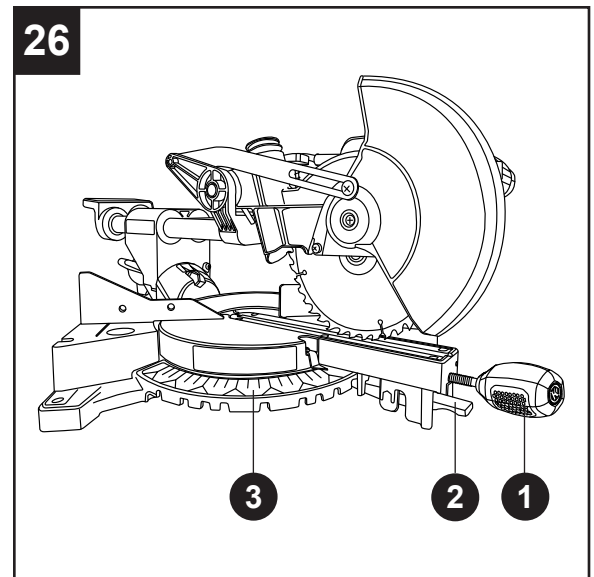

COMPOUND CUT (FIG. 28)

A compound cut is the combination of a miter and a bevel cut simultaneously.

- Loosen the bevel lock handle (1) and position the cutting head at the desired bevel position. Lock the bevel lock handle (1).
- Loosen the miter handle (2). Lift up the positive stop locking lever (3) and position the table at the desired angle. Release the positive stop locking lever (3) and lock the miter handle (2).

SLIDE CUTTING WIDE BOARDS UP TO 8 IN. WIDE (FIG. 29)

⚠ CAUTION: Always use a work clamp to maintain control and reduce the risk of workpiece damage and personal injury.

To avoid injury:

- Let the blade reach full speed before cutting. This will help reduce the risk of a thrown workpiece.
- Do not make crosscuts by lowering the blade and pulling the saw head through the wood toward you. The blade may try to climb up on top of the workpiece, causing the cutting assembly and spinning blade to kick back forcefully.

To Slide Cut Wide Boards (FIG. 29)

- Unlock the carriage lock handle (1) and allow the cutting head assembly to move freely.
- Set both the desired bevel angle and/or the miter angle and lock into position.
- Use a hold down clamp (2) to secure the workpiece (3).
- Grasp and pull the switch handle (4) forward until the center of the saw blade is over the front of the workpiece (3).
- Engage the trigger to turn the saw on.
- When the saw reaches full speed, slowly push the switch handle down, cutting through the leading edge of the workpiece.
- Slowly move the switch handle toward the fence, completing the cut.
- Release the trigger and allow the blade to stop spinning before raising the cutting head and removing the workpiece.

CUTTING BOWED MATERIAL (FIG. 30)

A bowed workpiece must be positioned against the fence and secured with a clamp (1) before cutting as shown. Do not position workpiece incorrectly or try to cut the workpiece without the support of the fence. This will cause the blade to bind and could result in personal injury.

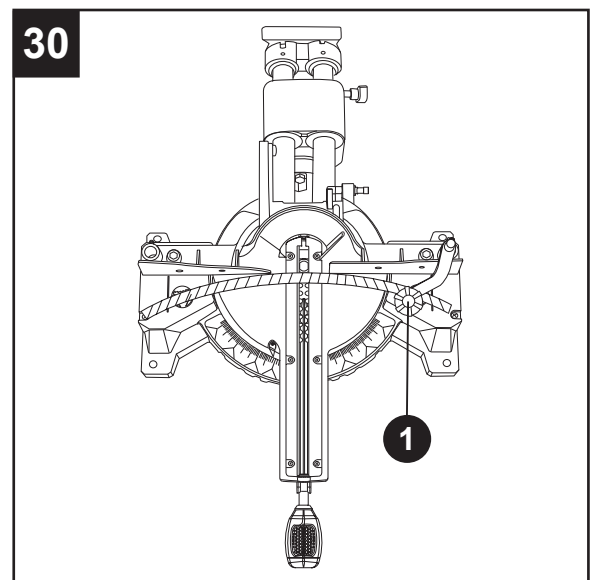
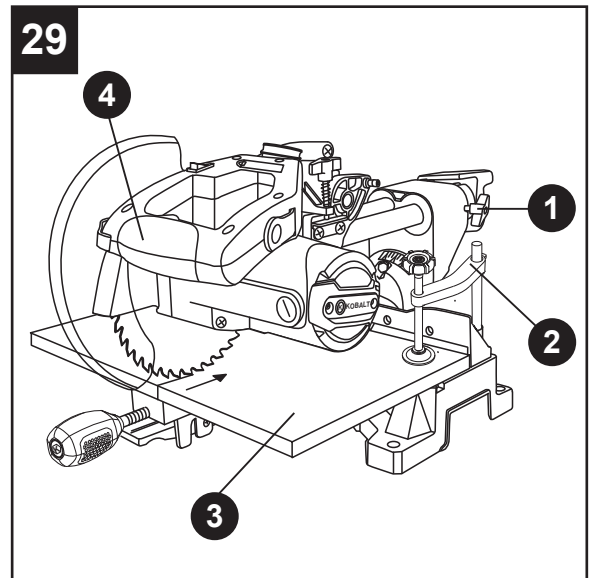
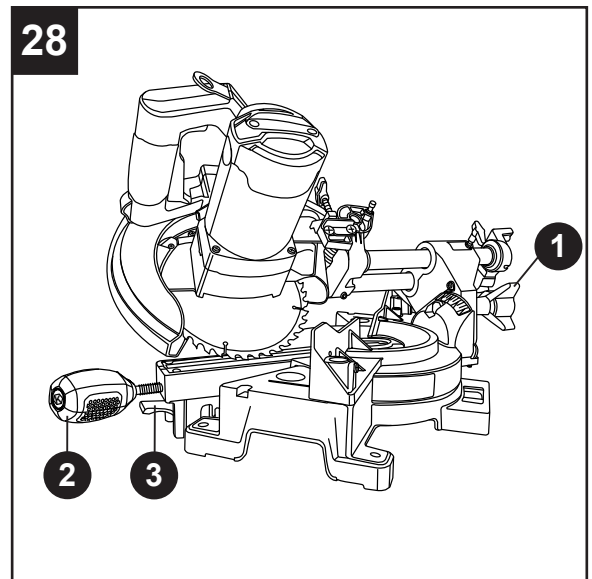

CUTTING GROOVES (FIG. 31)

⚠ WARNING: DO NOT USE A DADO BLADE, use only the standard saw blade for this operation.

- Mark lines to identify the width and depth of the desired cut on the workpiece and put the workpiece on the table and aim the inside tip of the blade at the line. Use a clamp to secure the workpiece on the table.
- Lower the cutting head so the tip of the blade touches the top surface of the workpiece at the marked line.
- While holding the upper arm in position, turn the stop knob (2) until it touches the stop plate (1). (SEE "SETTING CUTTING DEPTH" on page 21).
- Cut two parallel grooves as shown.

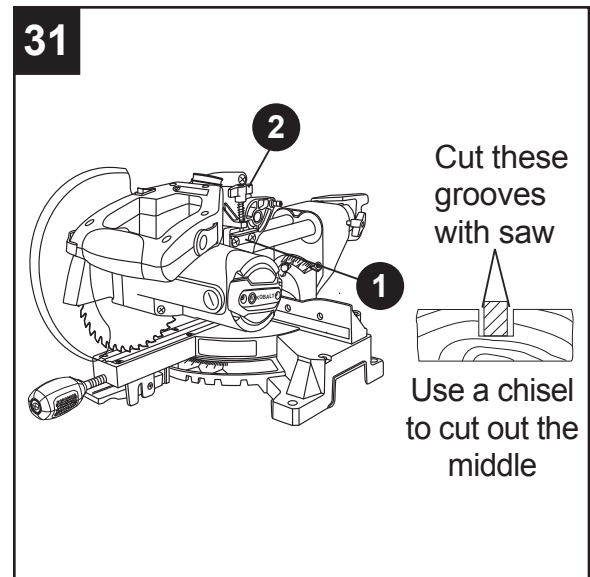

WORKPIECE SUPPORT (FIG. 32)

Long pieces need extra support. The support should be placed under the workpiece. Keep your hand holding the workpiece positioned 6-3/4 inches or more away from the blade. The support must let the workpiece lay flat on the work table during the cutting operation.

NOTE: When mounted on a flat surface, the saw table is 2-5/8 inches high.

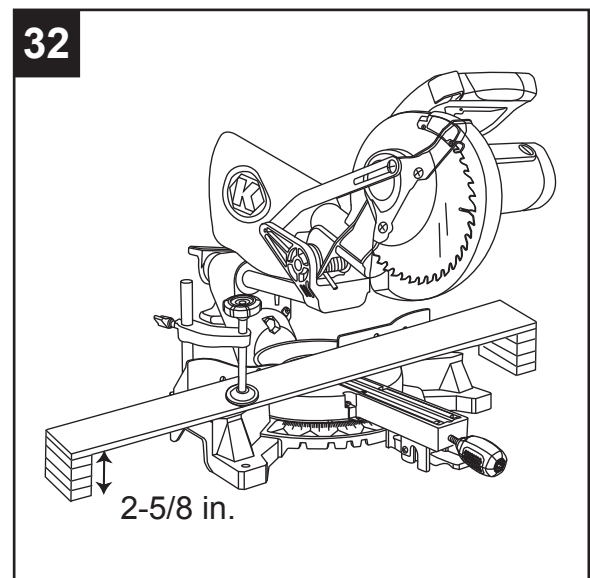

AUXILIARY WOOD FENCE (FIG. 33)

When making multiple or repetitive cuts that result in cut-off pieces of one inch or less, it is possible for the saw blade to catch the cut-off piece and throw it out of the saw or into the blade guard and housing, possibly causing damage or injury. To minimize this, an auxiliary wood fence can be mounted to your saw. Holes are provided in the saw fence to attach an auxiliary wood fence (this provides additional depth of cut). This fence should be constructed of straight auxiliary wood approximately 3/4 in. thick by 1-1/2 in. high by 16 in. long. Attach the wood fence securely and make a full depth cut to make a blade slot. Check for interference between the wood fence and the lower blade guard. Adjust if necessary.

NOTE: This auxiliary fence is used only with the saw blade in the 0° bevel position (90° to the table). The auxiliary wood fence must be removed when bevel cutting.

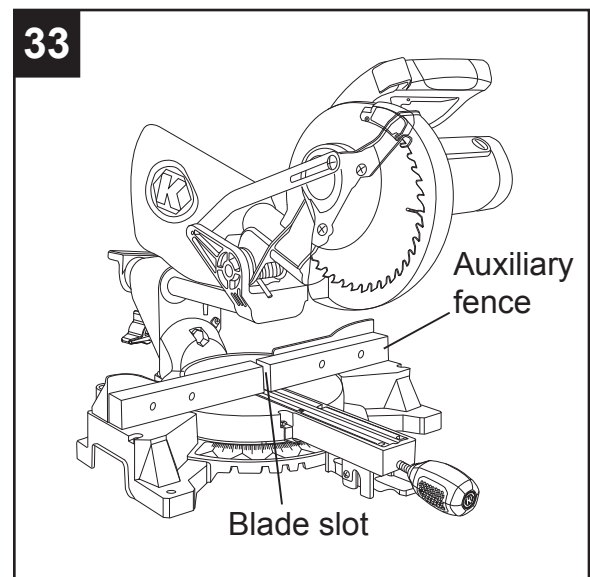

CUTTING BASE MOULDING (FIG. 34)

Base mouldings and many other mouldings can be cut on a compound miter saw. The setup of the saw depends on moulding characteristics and applications, as shown. Perform practice cuts on scrap material to achieve best results:

- Always make sure mouldings rest firmly against the fence and table. Use hold-down or C-clamps, whenever possible, and place tape on the area being clamped to avoid marks.
- Reduce splintering by taping the cut area prior to making cut. Mark cut line directly on the tape.
- Splintering typically happens due to wrong blade application and thickness of the material.

NOTE: Always perform a dry run cut so you can determine if the operation being attempted is possible before power is applied to the saw.

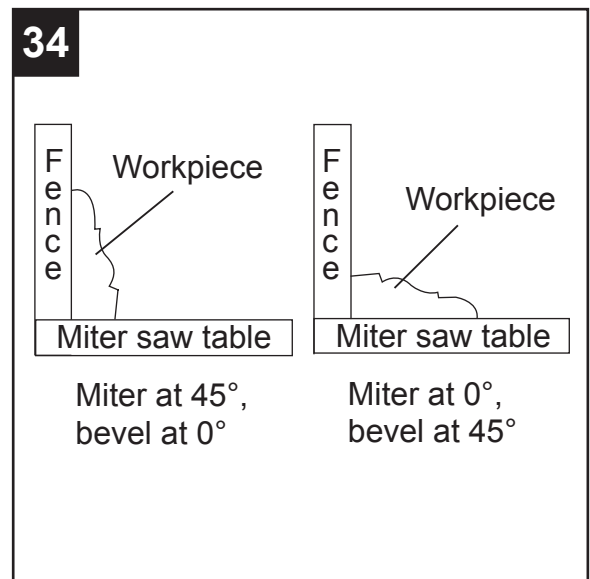

CUTTING CROWN MOULDING (FIG. 35, 36)

Your compound miter saw is suited for the difficult task of cutting crown moulding. To fit properly, crown moulding must be compound-mitered with extreme accuracy. The two surfaces on a piece of crown moulding that fit flat against the ceiling and wall are at angles that, **when added together, equal exactly 90°.**

Most crown moulding has a top rear angle (the section that fits flat against the ceiling) of 52° and a bottom rear angle (the section that fits flat against the wall) of 38°.

In order to accurately cut crown moulding for a **90° inside or outside corner**, lay the moulding with its broad back surface flat on the saw table.

When setting the bevel and miter angles for compound miters, remember the settings are interdependent; changing one changes the other, as well.

NOTE: The chart on the next page references a compound cut for crown moulding **ONLY WHEN THE ANGLE BETWEEN THE WALLS EQUALS 90°.**

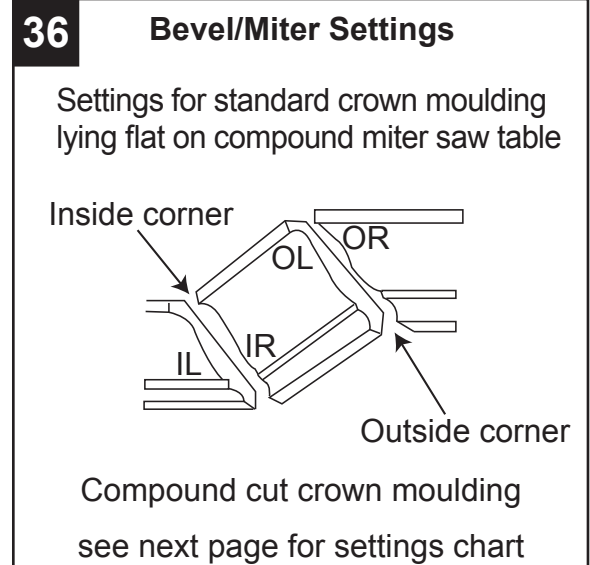
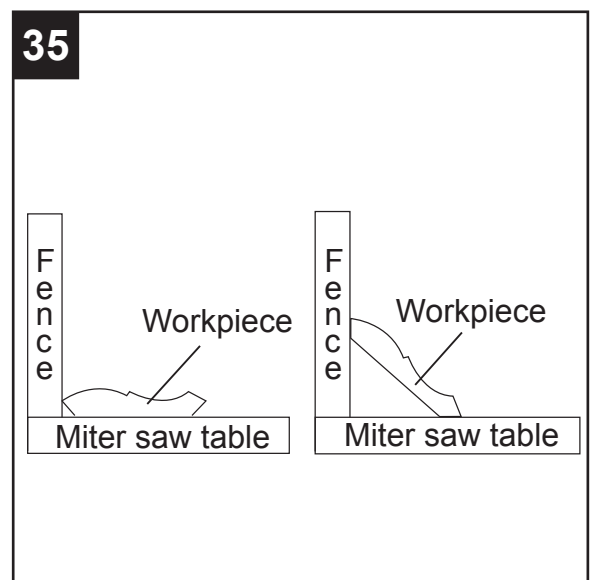

Bevel/Miter Settings

KEY	BEVEL SETTING	MITER SETTING	TYPE OF CUT
Inside corner - Left side			
IL	33.9°	31.6° Right	<ol style="list-style-type: none">1. Position top of moulding against fence.2. Miter table set at RIGHT 31.6°.3. LEFT side is finished piece.
Inside corner - Right side			
IR	33.9°	31.6° Left	<ol style="list-style-type: none">1. Position bottom of moulding against fence.2. Miter table set at LEFT 31.6°.3. LEFT side is finished piece.
Outside corner - Left side			
OL	33.9°	31.6° Left	<ol style="list-style-type: none">1. Position bottom of moulding against fence.2. Miter table set at LEFT 31.6°.3. RIGHT side is finished piece.
Outside corner - Right side			
OR	33.9°	31.6° Right	<ol style="list-style-type: none">1. Position top of moulding against fence.2. Miter table set at RIGHT 31.6°.3. RIGHT side is finished piece.

CROWN MOULDING CHART

Compound Miter Saw Miter and Bevel Angle Settings Wall to Crown Moulding Angle

Angle Between Walls	52/38° Crown Moulding		45/45° Crown Moulding	
	Miter Setting	Bevel Setting	Miter Setting	Bevel Setting
67	42.93	41.08	46.89	36.13
68	42.39	40.79	46.35	35.89
69	41.85	40.50	45.81	35.64
70	41.32	40.20	45.28	35.40
71	40.79	39.90	44.75	35.15
72	40.28	39.61	44.22	34.89
73	39.76	39.30	43.70	34.64
74	39.25	39.00	43.18	35.38
75	38.74	38.69	42.66	34.12
76	38.24	38.39	42.15	33.86
77	37.74	38.08	41.64	33.60
78	37.24	37.76	41.13	33.33
79	36.75	37.45	40.62	33.07
80	36.27	37.13	40.12	32.80
81	35.79	36.81	39.62	32.53
82	35.31	36.49	39.13	32.25
83	34.83	36.17	38.63	31.98
84	34.36	35.85	38.14	31.70
85	33.90	35.52	37.66	31.42
86	33.43	35.19	37.17	31.34
87	32.97	34.86	36.69	30.86
88	32.52	34.53	36.21	30.57
89	32.07	34.20	35.74	30.29
90	31.62	33.86	35.26	30.00
91	31.17	33.53	34.79	29.71
92	30.73	33.19	34.33	29.42
93	30.30	32.86	33.86	29.13
94	29.86	32.51	33.40	28.83
95	29.43	32.17	32.94	28.54
96	29.00	31.82	32.48	28.24
97	28.58	31.48	32.02	27.94
98	28.16	31.13	31.58	27.64
99	27.74	30.78	31.13	27.34
100	27.32	30.43	30.68	27.03
101	26.91	30.08	30.24	26.73
102	26.50	29.73	29.80	26.42
103	26.09	29.38	29.36	26.12
104	25.69	29.02	28.92	25.81
105	25.29	28.67	28.48	25.50
106	24.89	28.31	28.05	25.19
107	24.49	27.96	27.62	24.87
108	24.10	27.59	27.19	24.56
109	23.71	27.23	26.77	24.24
110	23.32	26.87	26.34	23.93
111	22.93	26.51	25.92	23.61
112	22.55	26.15	25.50	23.29
113	22.17	25.78	25.08	22.97
114	21.79	25.42	24.66	22.66
115	21.42	25.05	24.25	22.33
116	21.04	24.68	23.84	22.01
117	20.67	24.31	23.43	21.68
118	20.30	23.94	23.02	21.36
119	19.93	23.57	22.61	21.03
120	19.57	23.20	22.21	20.70
121	19.20	22.83	21.80	20.38

Angle Between Walls	52/38° Crown Moulding		45/45° Crown Moulding	
	Miter Setting	Bevel Setting	Miter Setting	Bevel Setting
122	18.84	22.46	21.40	20.05
123	18.48	22.09	21.00	19.72
124	18.13	21.71	20.61	19.39
125	17.77	21.34	20.21	19.06
126	17.42	20.96	19.81	18.72
127	17.06	20.59	19.42	18.39
128	16.71	20.21	19.03	18.06
129	16.37	19.83	18.64	17.72
130	16.02	19.45	18.25	17.39
131	15.67	19.07	17.86	17.05
132	15.33	18.69	17.48	16.71
133	14.99	18.31	17.09	16.38
134	14.66	17.93	16.71	16.04
135	14.30	17.55	16.32	15.70
136	13.97	17.17	15.94	15.36
137	13.63	16.79	15.56	15.02
138	13.30	16.40	15.19	14.62
139	12.96	16.02	14.81	14.34
140	12.63	15.64	14.43	14.00
141	12.30	15.25	14.06	13.65
142	11.97	14.87	13.68	13.31
143	11.64	14.48	13.31	12.97
144	11.31	14.09	12.94	12.62
145	10.99	13.71	12.57	12.29
146	10.66	13.32	12.20	11.93
147	10.34	12.93	11.83	11.59
148	10.01	12.54	11.46	11.24
149	9.69	12.16	11.09	10.89
150	9.37	11.77	10.73	10.55
151	9.05	11.38	10.36	10.20
152	8.73	10.99	10.00	9.85
153	8.41	10.60	9.63	9.50
154	8.09	10.21	9.27	9.15
155	7.77	9.82	8.91	8.80
156	7.46	9.43	8.55	8.45
157	7.14	9.04	8.19	8.10
158	6.82	8.65	7.83	7.75
159	6.51	8.26	7.47	7.40
160	6.20	7.86	7.11	7.05
161	5.88	7.47	6.75	6.70
162	5.57	7.08	6.39	6.35
163	5.26	6.69	6.03	6.00
164	4.95	6.30	5.68	5.65
165	4.63	5.90	5.32	5.30
166	4.32	5.51	4.96	4.94
167	4.01	5.12	4.61	4.59
168	3.70	4.72	4.25	4.24
169	3.39	4.33	3.90	3.89
170	3.08	3.94	3.54	3.53
171	2.77	3.54	3.19	3.10
172	2.47	3.15	2.83	2.83
173	2.15	2.75	2.48	2.47
174	1.85	2.36	2.12	2.12
175	1.54	1.97	1.77	1.77
176	1.23	1.58	1.41	1.41
177	0.92	1.18	1.06	1.06
178	0.62	0.79	0.71	0.71
179	0.31	0.39	0.35	0.35

CARE AND MAINTENANCE

⚠ WARNING

- To avoid fire or toxic reaction, never use gasoline, naphtha acetone, lacquer thinner or similar highly volatile solvents to clean the miter saw.
- To avoid injury from unexpected starting or electrical shock, unplug the power cord before working on the saw.
- For your safety, this saw is double insulated. To avoid electrical shock, fire or injury, use only parts identical to those identified in the parts list. Reassemble exactly to avoid electrical shock.

REPLACING CARBON BRUSHES (FIG. 37)

Replace both carbon brushes (3) when either has less than 1/4 in. length of carbon remaining, or if the spring or wire is damaged or burned. To inspect or replace brushes, first unplug the saw. Remove the black plastic cap (2) on the side of the motor (1). Use caution when removing the cap because it is springloaded. Pull out the brush and replace. Replace for the other side. To reassemble, reverse the procedure. Press the metal part of the carbon brush in the hole where the carbon part fits. Tighten the cap snugly but do not overtighten.

NOTE: To reinstall the same brushes, first make sure the brushes go back in the way they came out. This will avoid a break-in period that reduces motor performance and increases wear.

LOWER BLADE GUARD

Do not use the saw without the lower blade guard. The lower blade guard is attached to the saw for your protection. Should the lower guard become damaged, do not use the saw until the damaged guard has been replaced. Check regularly to make sure the lower guard is working properly. Clean the lower guard of any dust or buildup with a damp cloth.

⚠ CAUTION

- Do not use solvents on the guard. They could make the plastic cloudy and brittle.
- When cleaning the lower guard, unplug the saw to avoid unexpected start-up.

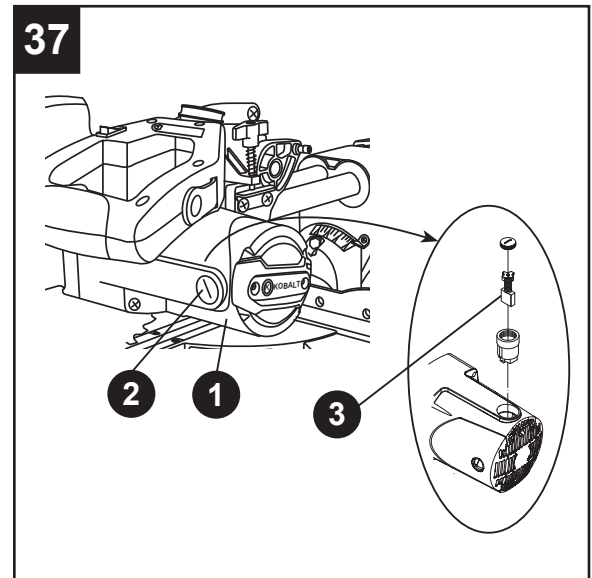

SAWDUST

Periodically, sawdust will accumulate under the worktable and base. This could cause difficulty in the movement of the worktable when setting up a miter cut. Frequently blow out or vacuum up the sawdust.

CAUTION

If blowing sawdust, wear proper eye protection to keep debris from blowing into eyes.

LUBRICATION (FIG. 38)

All the motor bearings in this tool are lubricated with a sufficient amount of high-grade lubricant for the life of the unit under normal operating conditions; therefore, no further lubrication is required.

Lubricate the following as necessary:

Chop pivot: Apply light machine oil to points indicated in illustration.

Central pivot of plastic guard: Use light household oil (sewing machine oil) on metal-to-metal or metal-to-plastic guard contact areas as required for smooth, quiet operation. Avoid excessive oil as sawdust will cling to it.

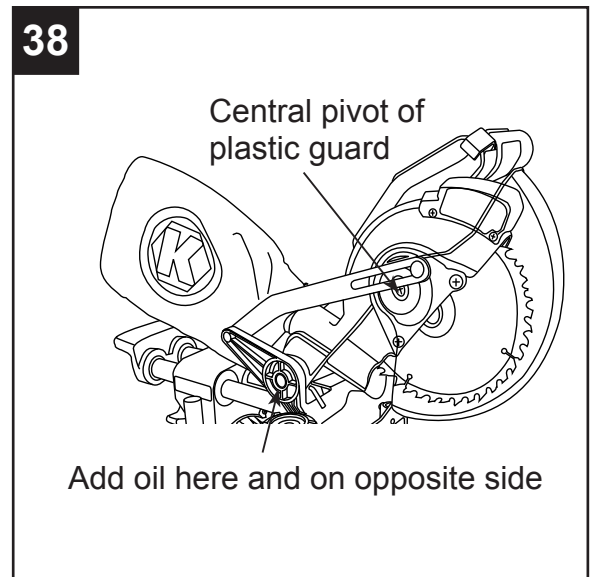

TROUBLESHOOTING

WARNING

To avoid injury from accidental starting, always ensure switch is in the OFF position and unplug the tool before moving, replacing the blade or making adjustments.

TROUBLESHOOTING – MOTOR

PROBLEM	POSSIBLE CAUSE	CORRECTIVE ACTION
Blade does not stop within 10 seconds.	<ol style="list-style-type: none">1. Motor brushes not sealed or lightly sticking.2. Arbor bolt loosened.3. Other.	<ol style="list-style-type: none">1. Inspect, clean and/or replace brushes. See CARE AND MAINTENANCE section.2. Retighten the arbor bolt.3. Contact customer service.
Motor does not start.	<ol style="list-style-type: none">1. Blown fuse.2. Worn brush.3. Other.	<ol style="list-style-type: none">1. Use and check the 15A time-delay fuse or the circuit breaker.2. See CARE AND MAINTENANCE section.3. Contact customer service.
Excessive brush spark when the switch is released.	<ol style="list-style-type: none">1. Brush worn.	<ol style="list-style-type: none">1. Replace brushes.

TROUBLESHOOTING – SAW OPERATION

PROBLEM	POSSIBLE CAUSE	CORRECTIVE ACTION
Blade hits table.	<ol style="list-style-type: none">1. Misalignment.	<ol style="list-style-type: none">1. See ADJUSTMENT section.
Angle of cut not accurate. Cannot adjust miter.	<ol style="list-style-type: none">1. Miter table locked.2. Sawdust under table.	<ol style="list-style-type: none">1. Push positive stop locking lever down and rotate table. See OPERATING INSTRUCTIONS section.2. Vacuum or blow out dust. WEAR EYE PROTECTION.
Cutting arm wobbles.	<ol style="list-style-type: none">1. Loose pivot points.	<ol style="list-style-type: none">1. See ADJUSTMENT INSTRUCTIONS section.
Cutting arm will not fully raise or blade guard will not fully close.	<ol style="list-style-type: none">1. Part failure.2. Pivot spring not replaced properly after service.3. Sawdust build-up.	<ol style="list-style-type: none">1. Contact customer service.2. Contact customer service.3. See CARE AND MAINTENANCE section.
Blade binds, jams, burns wood.	<ol style="list-style-type: none">1. Improper operation.2. Dull blade.3. Improper blade size.4. Warped blade.	<ol style="list-style-type: none">1. See BASIC SAW OPERATIONS section.2. Replace or sharpen blade.3. Replace with 7-1/4 in. diameter blade.4. Replace blade.
Saw vibrates or shakes.	<ol style="list-style-type: none">1. Saw blade not round2. Saw blade damaged.3. Saw blade loose.4. Saw blade warped.	<ol style="list-style-type: none">1. Replace blade.2. Replace blade.3. Tighten arbor bolt.4. Replace blade.

WARRANTY

The manufacturer will offer replacement parts for this product which under normal usage have proven to be defective in their manufacture or workmanship for a period of THREE (3) years from the date of initial retail purchase. This warranty is valid only to the original purchaser. This warranty is not transferable and does not cover any parts that have been subjected to misuse, abuse, alteration, overload, accident or normal wear of moving parts. Tools that have been sold "as is," sold reconditioned or used as rental equipment are not covered.

Warranty replacement parts can be obtained by contacting the manufacturer at 1-888-3KOBALT. Only the manufacturer is authorized to perform warranty service on this product. This warranty does not apply to accessories or damage caused where repairs have been made or attempted by others.

The manufacturer is not responsible for direct, indirect, incidental or consequential damages. Some states do not allow limitations on how long an implied warranty lasts and/or do not allow the exclusion or limitation of incidental damages, so the above limitations may not apply to you. This warranty gives you specific legal rights, and you may also have other rights, which vary from state to state.

The manufacturer makes no warranties, representations or promises as to the quality of its power tools other than those specially stated in this warranty.

WARRANTY VOID IF PRODUCT USED FOR COMMERCIAL PURPOSES.

For replacement parts, call our customer service department at 1-888-3KOBALT (1-888-356-2258).

REPLACEMENT PARTS LIST - SAW (PART A)

I.D.	Description	Size	Q'ty	I.D.	Description	Size	Q'ty
X4NP	MOTOR ASS'Y		1	X4PY	DUST BAG		1
X4P0	CR. RE. PAN HD. SCREW	M5*55	1	X4PZ	LASER COVER		1
X4P1	BATTERY (AAA)		2	X4Q0	LASER LABEL (LEFT)		1
X4P2	BATTERY BOX		1	X4Q1	CR. RE. COUNT HD. SCREW	M4*8	7
X4P3	BUTTON SWITCH		1	X4Q2	ANTI-DUST PLATE		1
X4P4	CR. RE. PAN HD. TAPPING SCREW	ST3.9*14	2	X4Q6	HEX. SOC. SET SCREW	M6*10	2
X4P5	CORD CLAMP		1	X4Q7	COMPRESSION SPRING		1
X4P6	POWER CABLE		1	X4Q8	CLAMP BOLT		1
X4P7	GUARD-CORD		1	X4QL	LABEL		1
X4P8	MOTOR HANDLE (DOWN)		1	X4QY	CR. RE. PAN HD. SCREW	M4*12	1
X4P9	BUTTON SWITCH		1	X4QZ	BLADE		1
X4PA	LIMIT SWITCH		1	X4R0	ARBOR COLLAR		2
X4PB	TRIGGER		1	X4R1	ARBOR BOLT	M8*16	1
X4PC	MOTOR HANDLE (TOP)		1	X4R2	CUTTER SHAFT GUARD		1
X4PD	CR. RE. PAN HD. TAPPING SCREW	ST3.9*16	4	X4R3	CR. RE. PAN HD. SCREW	M6*10	1
X4PE	BLADE WRENCH		1	X4R5	CR. RE. PAN HD. ROUND NECK SCREW	M6*9	1
X4PF	LASER SWITCH		1	X4R6	SPRING GUARD		1
X4PG	BATTERY COVER		1	X4R7	LOCK NUT	M6	2
X4PH	LABEL		1	X4R8	PC-GUARD		1
X4PL	CR. RE. PAN HD. SCREW	M5*30	1	X4R9	BRACING PLATE		1
X4PP	CABLE SHELL		1	X4RA	LEVER		1
X4PQ	LABEL		1	X4RC	COLLAR		1
X4PR	WAVE WASHER	φ5	2	X4RD	CR. RE. COUNT HD. SCREW	M6*20	1
X4PS	LASER SET		1	X4RQ	FLAT WASHER	φ6	3
X4PT	FLAT WASHER	φ3	2	X4S6	SPECIAL SCREW	M6*12	2
X4PU	CR. RE. PAN HD. SCREW	M3*8	2	X4S7	WAVE WASHER	φ8	1
X4PV	HEX. SOC. SET SCREW	M4*6	1	X4SX	CROSS PAN HEAD SCREW	M5*40	1
X4PW	LASER ASS'Y		1	X4XK	COMPRESSION SPRING		1
X4PX	LASER LABEL (RIGHT)		1				

EXPLODED VIEW - SAW (PART A)

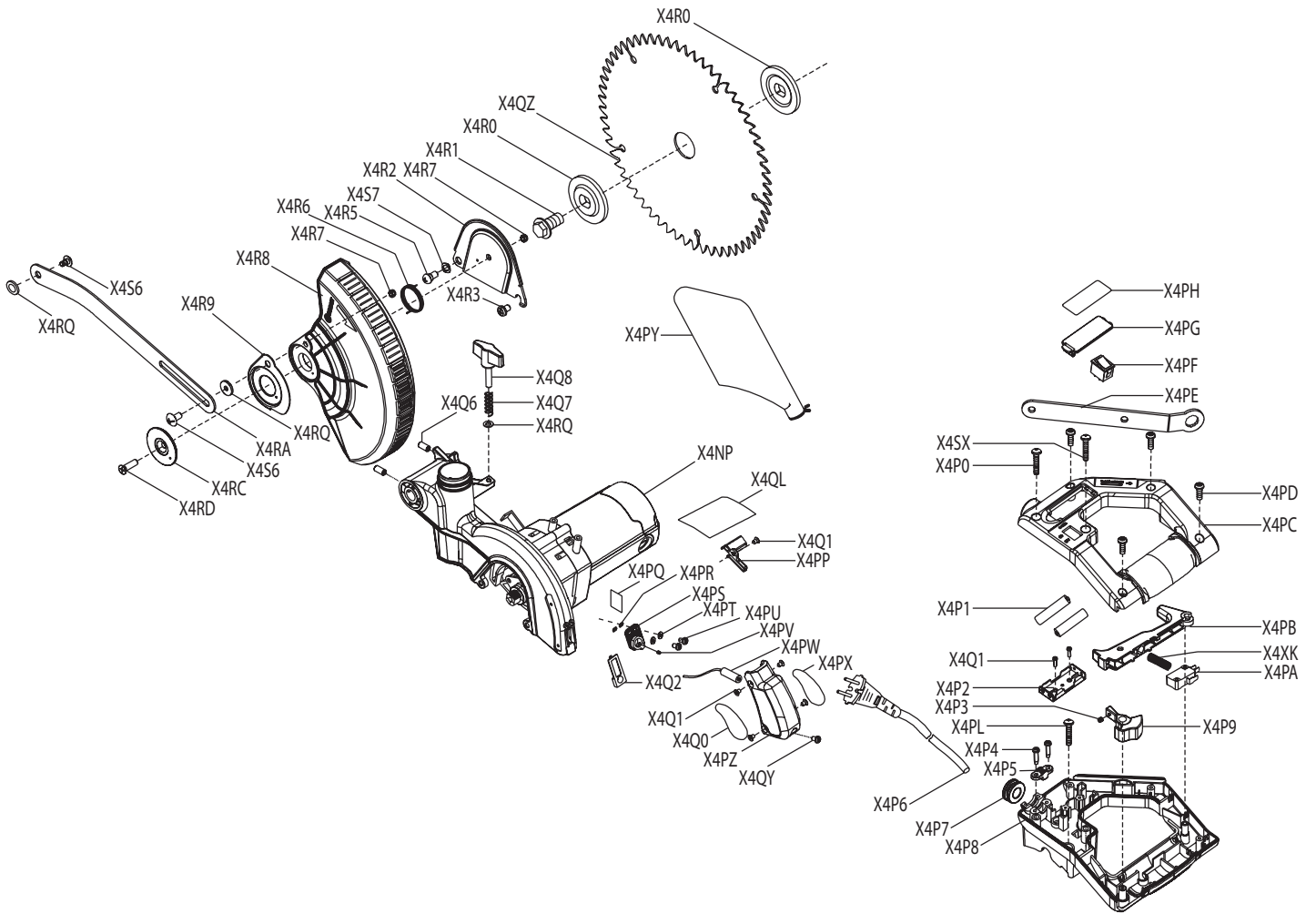

REPLACEMENT PARTS LIST - SAW (PART B)

I.D.	Description	Size	Q'ty	I.D.	Description	Size	Q'ty
X4NQ	SWIVEL SUPPORT ASS'Y		1	X4S8	LOCATION PLATE		1
X4NR	WISE ASS'Y		1	X4SB	HEX. HD. BOLT	M10*65	1
X4NS	OPERATOR'S MANUAL		1	X4SD	HEX. NUT	M6	2
X4NU	WING SCREW	M6*18	1	X4SE	TILTING SCALE		1
X4Q6	INNER HEX. SCREW	M6*10	1	X4SF	LOCK NUT	M8	1
X4RG	HOLD DOWN CLAMP ASS'Y		1	X4SG	FLAT WASHER	φ8	1
X4RH	FLAT WASHER	φ10	1	X4SH	CR. RE. PAN HD. SCREW	M4*6	6
X4RJ	LOCK NUT	M12	1	X4SJ	TABLE INSERT (RIGHT)		1
X4RK	FLAT WASHER	φ12	1	X4SK	TABLE INSERT (LEFT)		1
X4RL	WARNING LABEL		1	X4SL	LABEL		1
X4RM	ARM-MITER		1	X4SM	TABLE		1
X4RN	CLAMP BOLT	M6*25	1	X4SN	CR. RE. PAN HD. SCREW	M5*35	1
X4RP	COMPRESSION SPRING		1	X4SR	PLUNGER HANDLE		1
X4RQ	FLAT WASHER	φ6	1	X4SS	COMPRESSION SPRING		1
X4RR	TILT POINTER		1	X4ST	LOCK NUT	M5	1
X4RS	LINEAR MOTION BEARING		1	X4SU	NEEDLE POINTER		1
X4RT	BEARING COVER		1	X4SV	CR. RE. PAN HD. SCREW	M5*8	2
X4RU	O-RING		2	X4SW	STEEL PIECE		3
X4RV	CR. RE. PAN HD. SCREW	M6*8	1	X4SY	LABEL		1
X4RW	LINEAR MOTION BEARING		1	X4SZ	HEX. SOC. HD. CAP BOLT	M10*25	2
X4RX	SHAFT		1	X4T0	FLAT WASHER	φ10	2
X4RY	SHAFT SLEEVE		1	X4T1	CR. RE. PAN HD. SCREW	M6*12	2
X4RZ	TORSION SPRING		1	X4T2	FENCE		1
X4S0	SHAFT-PIVOT		1	X4T3	LABEL		1
X4S2	HEX. HD. BOLT	M6*20	2	X4T4	TABLE AXIS		1
X4S3	O-RING		1	X4T5	SCALE		1
X4S4	CLEVIS PIN		1	X4T6	BASE		1
X4S5	C-RING		1	X4T7	LABEL		1
X4S6	CR. RE. TRUSS HD. ROUND NECK SCREW	M6*10	2	X4XJ	LOCKING HANDLE ASS'Y		1
X4S7	WAVE WASHER	φ8	2				

EXPLODED VIEW - SAW (PART B)

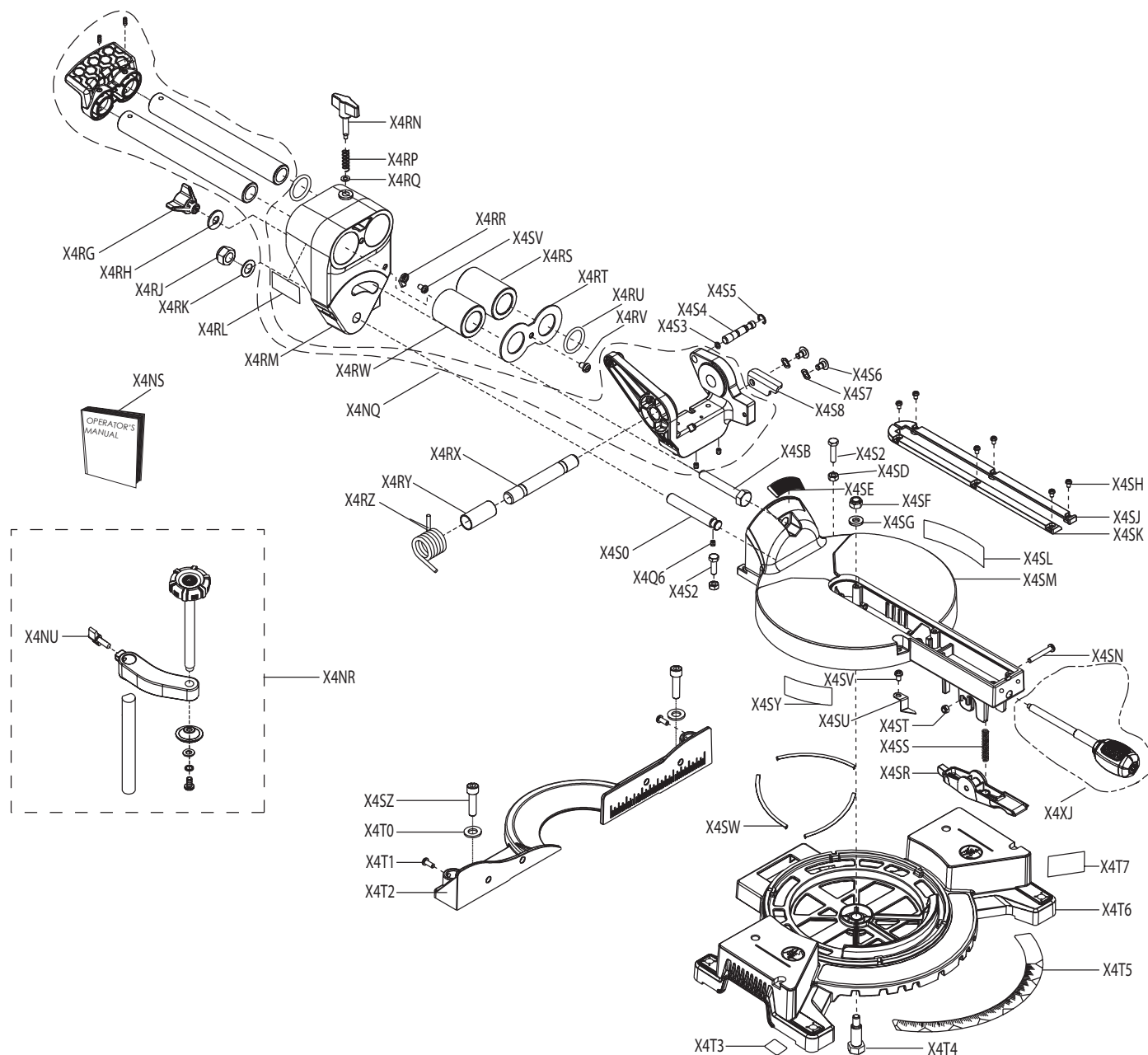

REPLACEMENT PARTS LIST - MOTOR

I.D.	Description	Size	Q'ty
X4PJ	FLAT WASHER	φ5	3
X4PK	SPRING WASHER	φ5	5
X4PL	CR. RE. PAN HD. SCREW	M5*30	3
X4PM	BEARING		1
X4PN	SPRING		1
X4Q3	ARM		1
X4Q4	ARBOR LOCK		1
X4Q5	SHELL		1
X4Q9	STOPPING WIND PLATE		1
X4QA	ARMATURE ASS'Y		1
X4QB	BEARING		1
X4QC	CR. RE. PAN HD. TAPPING SCREW	ST4.8*72	2
X4QD	FIELD ASS'Y		1
X4QE	BODY SHELL		1
X4QF	BRUSH HOLDER ASS'Y		2
X4QG	CARBON BRUSH ASS'Y		2
X4QH	BRUSH COVER		2
X4QJ	MOTOR END COVER		1
X4QK	CR. RE. PAN HD. SCREW	M4*12	2
X4QM	BALL BEARING		1
X4QN	C-RING	φ12	1
X4QP	GEAR		1
X4QQ	C-RING	φ15	1
X4QR	BEARING SEAT		1
X4QS	BEARING		1
X4QT	SEMI-CIRCLE KEY		1
X4QU	BEARING SHAFT		1
X4QV	BEARING COVER		1
X4QX	CR. RE. PAN HD. SCREW	M4*16	2

EXPLODED VIEW - MOTOR

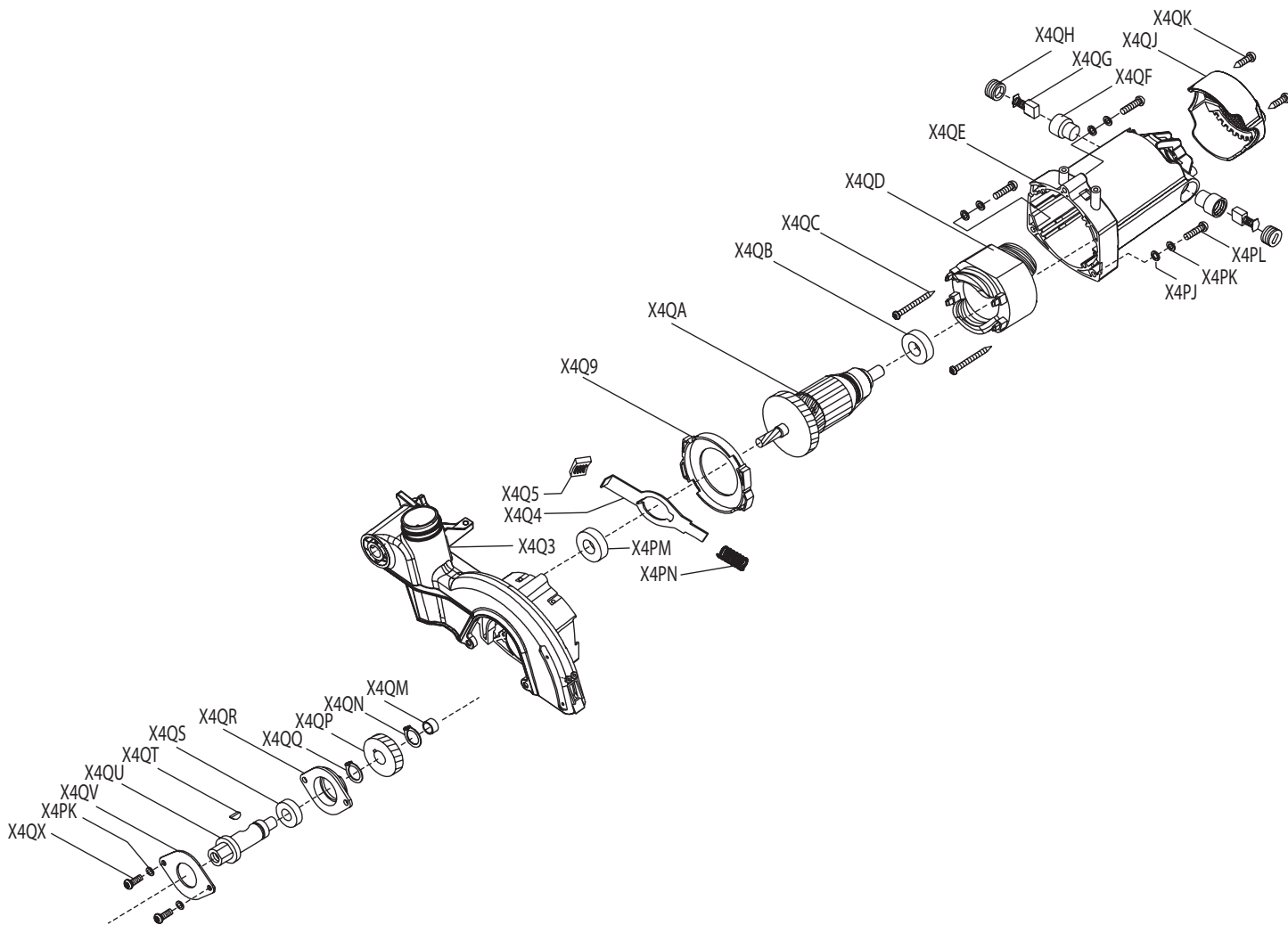

PAGE INTENTIONALLY LEFT BLANK